



600 County Road D W, Suite 14  
New Brighton, MN 55112  
July 10, 2018

Jane Doe. PE  
Doe Engineering  
2000 – 3<sup>rd</sup> Street  
Somewhere, USA 00000

RE: SAFL Baffle Sediment Removal for 36<sup>th</sup> Street

Ms Doe:

This letter is a summary of sediment removal efficiency analyses for eight proposed sump manholes with SAFL Baffles for the 36<sup>th</sup> Street improvements project. This analysis was performed using SHSAM software by Barr Engineering.

#### *Recommended Sump Size*

The following tables provides the sediment removal efficiencies for various sump sizes at each location. The recommended size for each location is highlighted in yellow. Some SAFL Baffle structures show less than 80% sediment removal efficiency, while others show more than 80%. The goal was to achieve an average of 80% or more sediment removal across the site. The method for calculating the project weighted average sediment removal is shown in the table at the top of Page 4. This weighted average sediment removal efficiency for the project is 84 percent. If you need each SAFL Baffle location to individually achieve 80% or greater TSS removal, you can increase the size of the SAFL Baffle and sump according to the following tables.

#### **Looking Glass**

<i>Sump Diameter (feet)</i>	<i>Sump Depth (feet)</i>	<i>Sediment Removal Efficiency (%)</i>
4	2	45.2
4	4	63.0
5	5	71.4
6	3	64.3
6	6	77.3
8	6	81.2
10	6	83.8

### Schumann Drive

<i>Sump Diameter (feet)</i>	<i>Sump Depth (feet)</i>	<i>Sediment Removal Efficiency (%)</i>
4	2	60.2
4	4	75.5
5	5	82.2
6	3	76.5
<b>6</b>	<b>6</b>	<b>86.2</b>
8	6	88.9
10	6	90.5

### Lynnwood

<i>Sump Diameter (feet)</i>	<i>Sump Depth (feet)</i>	<i>Sediment Removal Efficiency (%)</i>
4	2	67.6
4	4	81.1
5	5	86.3
6	3	82.0
<b>6</b>	<b>6</b>	<b>89.7</b>
8	6	91.7
10	6	93.1

### South of Leawood

<i>Sump Diameter (feet)</i>	<i>Sump Depth (feet)</i>	<i>Sediment Removal Efficiency (%)</i>
4	2	64.1
4	4	79.1
5	5	84.8
6	3	80.1
<b>6</b>	<b>6</b>	<b>88.5</b>
8	6	90.7
10	6	92.2

### North of Leawood

<i>Sump Diameter (feet)</i>	<i>Sump Depth (feet)</i>	<i>Sediment Removal Efficiency (%)</i>
4	2	47.2
4	4	65.4
5	5	73.8
6	3	66.7
<b>6</b>	<b>6</b>	<b>79.4</b>
8	6	83.0
10	6	85.5

### North of Capehart

<i>Sump Diameter (feet)</i>	<i>Sump Depth (feet)</i>	<i>Sediment Removal Efficiency (%)</i>
4	2	91.2
4	4	95.6
5	5	97.3
6	3	96.2
6	6	98.2
8	6	98.7
10	6	99.1

### Lockbourne

<i>Sump Diameter (feet)</i>	<i>Sump Depth (feet)</i>	<i>Sediment Removal Efficiency (%)</i>
4	2	66.2
4	4	80.3
5	5	85.8
6	3	81.1
6	6	89.2
8	6	91.3
10	6	92.8

### Granada

<i>Sump Diameter (feet)</i>	<i>Sump Depth (feet)</i>	<i>Sediment Removal Efficiency (%)</i>
4	2	56.8
4	4	73.4
5	5	80.5
6	3	74.4
6	6	84.8
8	6	87.7
10	6	89.7

### *Weighted Site Sediment Removal*

The following table shows the weighted average sediment removal for all of the SAFL Baffle structures across the project.

<i>Structure Name</i>	<i>Drain Area (acres)</i>	<i>Percent of Site Acres</i>	<i>Sediment Removal (%)</i>	<i>Weighted Site Sediment Removal (%)</i>
Looking Glass	31.60	24	77.3	18.5
Schumann Dr.	24.73	19	86.2	16.2
Lynnwood	15.24	12	89.7	10.4
South of Leawood	16.84	13	88.5	11.3
North of Leawood	15.91	12	79.4	9.6
North of Capehart	3.47	3	98.2	2.6
Lockbourne	12.2	9	89.2	8.3
Granada	11.9	9	84.8	7.7
<b>Totals</b>	<b>131.89</b>			<b>84.4%</b>

#### *Inputs to SHSAM Software*

The SHSAM software used for this analysis was developed by Barr Engineering in Minneapolis and is based on data from several years of testing at the University of Minnesota's St. Anthony Falls Laboratory. SHSAM performs a continuous rainfall model, calculating sediment removal for each storm event over several years of rainfall data. It then calculates an average sediment removal efficiency for all the years in the analysis. This overall average is reported in the table above.

The software is available at no charge at the following website:

<https://shsam.barr.com/>

The inputs used for the analysis on this project are summarized in the following table:

<i>Structure Name/Number</i>	<i>Diameter of Inlet Pipe (inches)</i>	<i>Drain Area (acres)</i>	<i>Slope (%)</i>	<i>Percent Impervious Area</i>	<i>Curve Number for Impervious Area</i>
Looking Glass	36	31.60	1	40	70
Schuman Dr.	42	24.73	1	40	70
Lynwood	36	15.24	1	40	70
South of Leawood	36	16.84	1	40	70
North of Leawood	24	15.91	1	40	70
North of Capehart	30	3.47	1	40	70
Lockbourne	30	12.2	1	40	70
Granada	24	11.9	1	40	70

You provided us with the drainage area and percent impervious area at each location, along with the average slope. The location of each SAFL Baffle structure is shown on the attached plan sheets.

The analysis used NOAA 15-minute precipitation files from a weather station in Gretna, Nebraska. The precipitation data was continuous from 1982 to 2012. Sediment concentration was set at 250 mg/L. Sediment removal efficiency was calculated for the particle size distribution shown in the figure below. These sediment removal efficiencies are reported in the tables on Pages 1 through 3.

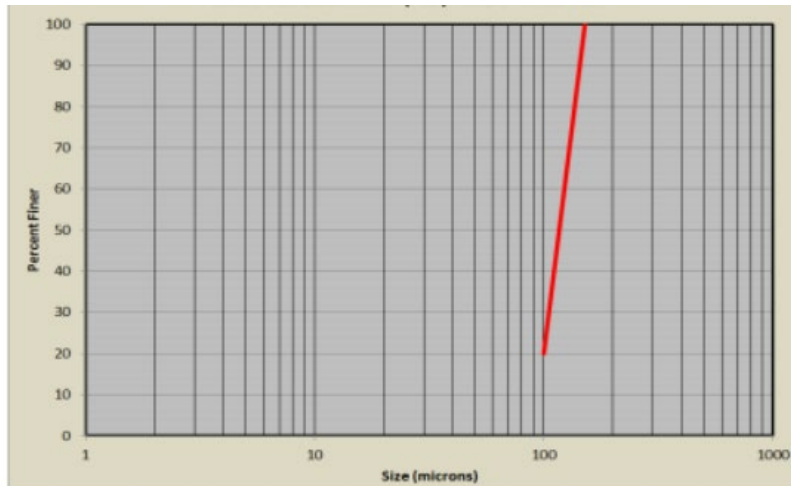

### *Maintenance*

Maintenance of the SAFL Baffle consists of removing the captured sediment from the sump, using a vacuum truck. Use the high-pressure washer on the vacuum truck to knock off any leaves or other debris that is stuck to the SAFL Baffle. Remove the accumulated sediment when the top of the sediment is 12 inches below the bottom of the SAFL Baffle. The analysis for this site indicates that the sump will fill with sediment twice per year.

Please call me at 651-237-5123 if you have any questions about these recommendations or how the analysis was performed.

Sincerely,

A.J. Schwidder, PE  
Upstream Technologies Inc.

# 36TH STREET



**CONSTRUCT REINFORCED CONCRETE PIPE**

No.	LOCATION	SIZE	REMARKS
1	C.I. NO. C1 TO C.I. NO. C2	15" X 42'	GR.=3.46%
2	C.I. NO. C2 TO C.I. NO. C3	30" X 189'	GR.=4.77%
3	C.I. NO. C3 TO M.H. NO. C1	36" X 134'	GR.=5.25%
4	M.H. NO. C1 TO M.H. NO. C2	36" X 94'	GR.=19.82%
5	C.I. NO. C4 TO C.I. NO. C5	15" X 42'	GR.=3.07%
6	C.I. NO. C5 TO M.H. NO. C1	30" X 87'	GR.=4.11%
7	M.H. NO. C3 TO M.H. NO. C1	30" X 35'	GR.=20.26%

**CONSTRUCT CURB INLET - STD. PLT. 700-21**

No.	LOCATION	TYPE	"X"	"A"	"S"	F.L.=
1	STA. 185+92.54, 4.00 LT. N 491144.67, E. 2752199.78	I	X.XX'	X.XX'	X.XX'	1119.20 (15'E)
2	STA. 185+92.54, 34.00 RT. N 491146.44, E. 2752237.74	II	X.XX'	X.XX'	X.XX'	1117.76 (15'W) 1113.00 (30'S) 1113.00 (30'N)
3	STA. 187+81.44, 34.00 RT. N 491335.13, E. 2752228.94	III	X.XX'	X.XX'	X.XX'	1104.00 (30'S) 1103.50 (36'N)
4	STA. 189+99.89, 4.00 LT. N 491551.57, E. 2752180.79	I	X.XX'	X.XX'	X.XX'	1103.07 (15'E) 1103.07 (15'W) FUTURE
5	STA. 189+99.89, 34.00 RT. N 491553.34, E. 2752218.74	III	X.XX'	X.XX'	X.XX'	1101.79 (15'W) 1100.54 (30'S) 1101.04 (24'N)

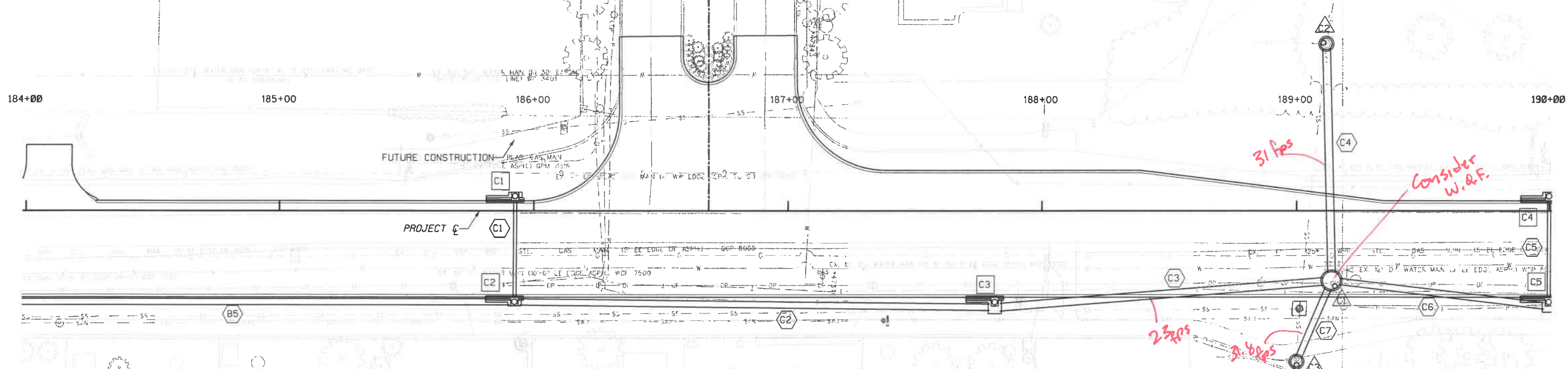

**SAFL Baffle structure will be added at yellow circle.**

**CONSTRUCT MANHOLE - STD. PLT. 700-40**

No.	LOCATION	SIZE	V.F.	F.L.=	REMARKS
1	STA. 189+13.87, 27.50 RT. N 491467.11, E. 2752216.27	84" I.D.	X.XX	1096.50 (36'S), 1096.50 (36'W) 1097.00 (30'N), 1097.00 (30'SE)	FLAT-TOP C.I.P.
2	STA. 189+11.36, 65.82 LT. N 491460.25, E. 2752123.17	54" I.D.	X.XX	1073.15 (15'S) EXIST, 1078.00 (36'E) 1073.15 (36'W) EXIST	C.I.P.
3	STA. 189+00.30, 59.46' RT. N 491455.05, E. 2752248.83	54" I.D.	X.XX	1104.06 (30'NE) 1107.17 (30'S) EXIST.	C.I.P.

*Velocity Mitigation*

*Looking Glass*

STA. 184+00.00 TO STA. 190+00.00



**DRAINAGE**

# 36TH STREET

**CONSTRUCT REINFORCED CONCRETE PIPE**

No.	LOCATION	SIZE	REMARKS
1	M.H. NO. D1 TO C.I. NO. C5	24" X 47'	GR.=1.32%
2	C.I. NO. D1 TO M.H. NO. D1	24" X 39'	GR.=2.05%
3	C.I. NO. D2 TO C.I. NO. D1	15" X 36'	GR.=2.94%
4	C.I. NO. D3 TO C.I. NO. D4	15" X 264'	GR.=1.90%
5	C.I. NO. D4 TO M.H. NO. D2	18" X 70'	GR.=1.71%
6	C.I. NO. D6 TO M.H. NO. D2	42" X 42'	GR.=4.26%
7	C.I. NO. D5 TO C.I. NO. D6	42" X 29'	GR.=3.49%
8	C.I. NO. D7 TO M.H. NO. D2	15" X 39'	GR.=4.58%
9	M.H. NO. D2 TO M.H. NO. E1	42" X 210'	GR.=2.96%
10	C.I. NO. D8 TO C.I. NO. D5	42" X 43'	GR.=6.44%

**CONSTRUCT CURB INLET - STD. PLT. 700-21**

No.	LOCATION	TYPE	"X"	"A"	"S"	F.L.=
1	STA. 600+74.50, 16.00 RT. N 491602.87, E 2752256.97	III	X.XX'	X.XX'	X.XX'	1103.37 (15°N), 1102.45 (24°W) 1102.45 (18°E) EXIST
2	STA. 600+74.50, 16.00 LT. N 491634.84, E 2752255.48	I	X.XX'	X.XX'	X.XX'	1104.42 (15°S)
3	STA. 192+37.00, 34.00 RT. N 491790.19, E 275207.66	I	X.XX'	X.XX'	X.XX'	1098.15 (15°N)
4	STA. 195+00.27, 34.00 RT. N 492053.17, E 2752195.36	III	X.XX'	X.XX'	X.XX'	1093.14 (15°S) 1092.89 (18°N)
5	STA. 700+74.50, 12.50 N 492095.52, E 2752233.92	III	X.XX'	X.XX'	X.XX'	1091.50 (42°N) 1091.50 (42°E)
6	STA. 700+74.50, 12.50 LT. N 492120.49, E 2752232.75	III	X.XX'	X.XX'	X.XX'	1091.95 (36°W) 1091.95 (36°S)
7	STA. 195+69.72, 4.00 LT. N 492120.78, E 2752154.16	I	X.XX'	X.XX'	X.XX'	1093.70 (15°E)
8	STA. 701+17.13, 12.50 RT. N 492097.51, E 2752276.51	III	X.XX'	X.XX'	X.XX'	1095.24 (42°W)

**CONSTRUCT MANHOLE - STD. PLT. 700-40**

No.	LOCATION	SIZE	V.F.	F.L.=	REMARKS
1	STA. 190+46.04, 37.33 RT. N 491599.60, E 2752219.92	54" I.D.	X.XX	1101.65 (24°E) 1101.65 (24°S)	FLAT-TOP
2	STA. 195+69.29, 32.19 RT. N 492122.04, E 2752190.32	84" I.D.	X.XX	1091.70 (18°S), 1089.70 (42°E) 1091.95 (15°W), 1089.70 (42°N)	FLAT-TOP

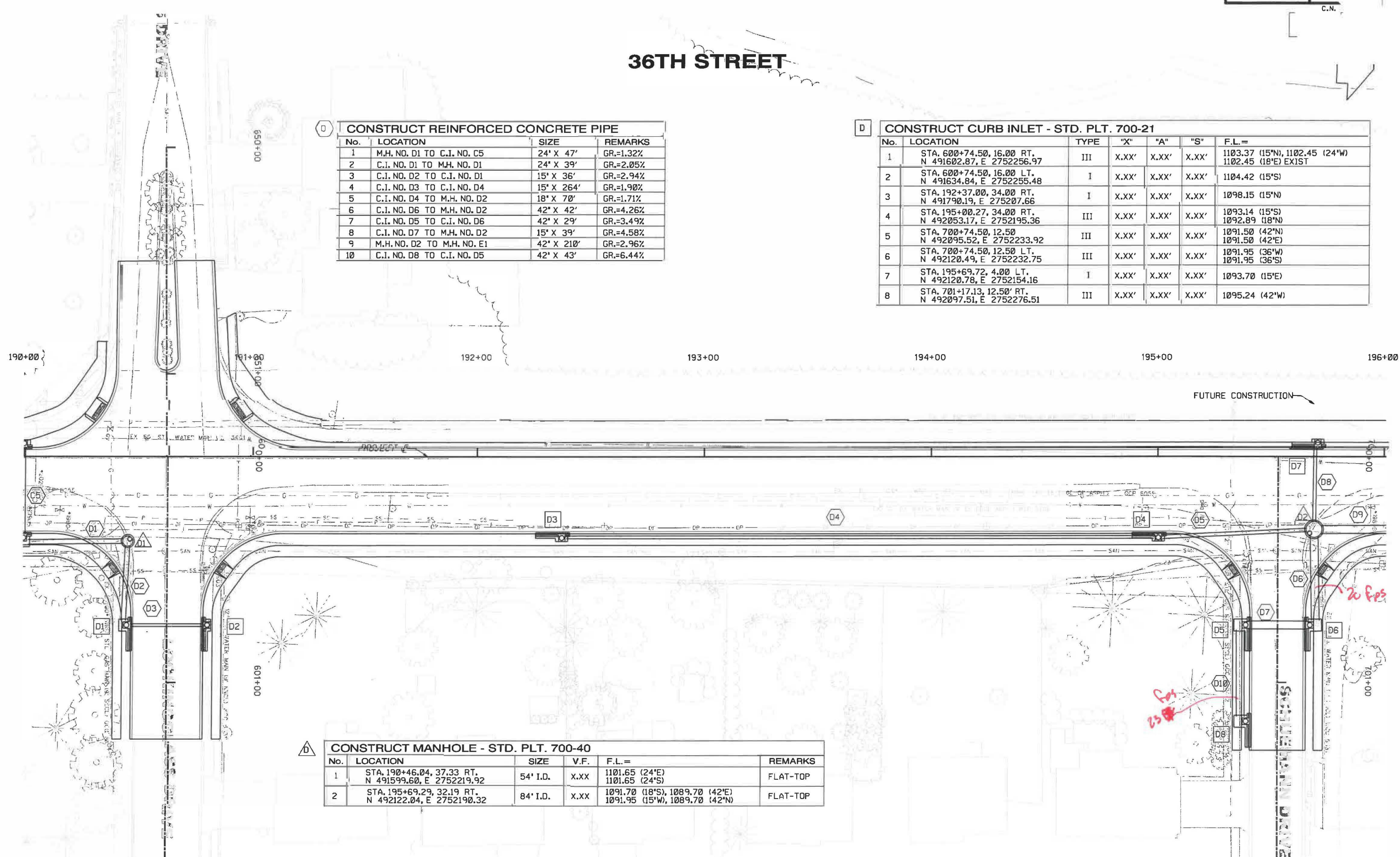

STA. 190+00.00 TO STA. 196+00.00



## DRAINAGE

# 36TH STREET

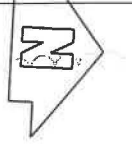

**E CONSTRUCT REINFORCED CONCRETE PIPE**

No.	LOCATION	SIZE	REMARKS
1	M.H. NO. E2 TO F.E.S. NO. E1	42" X 22"	GR.=4.52%
1A	C.I. NO. E2 TO MH. NO. E2	42" X 34"	GR.=16.61%
2	C.I. NO. E1 TO C.I. NO. E2	42" X 42"	GR.=3.60%
3	A.I. NO. E1 TO M.H. NO. E1	15" X 30"	GR.=3.42%
3A	MH. NO. E1 TO C.I. NO. E1	42" X 31"	GR.=1.62%
3B	C.C. NO. E1 TO C.I. NO. E1	24" X 16"	GR.=4.70%
4	C.I. NO. E1 TO C.I. NO. E3	24" X 136"	GR.=0.99%
5	C.I. NO. E4 TO C.I. NO. E3	15" X 42"	GR.=1.08%
6	C.I. NO. E5 TO C.I. NO. E3	24" X 73"	GR.=0.55%
7	C.I. NO. E6 TO C.I. NO. E5	15" X 42"	GR.=0.48%
8	C.I. NO. E7 TO C.I. NO. E5	24" X 80"	GR.=0.63%
9	C.I. NO. E8 TO C.I. NO. E7	15" X 44"	GR.=0.46%

*Schumann Dr.*

**SAFL Baffle structure is highlighted in yellow.**

**E CONSTRUCT CURB INLET - STD. PLT. 700-21**

No.	LOCATION	TYPE	"X"	"A"	"S"	F.L.=
1	STA. 198+10.00, 34.00' RT. N 492362.56, E 2752180.89	III	X.XX'	X.XX'	X.XX'	1083.00 (42"W) 1084.50 (24"N) 1083.00 (42"SW) 1084.50 (24"NE)
2	STA. 198+10.00, 4.00' LT. N 492360.79, E 2752142.93	III	X.XX'	X.XX'	X.XX'	1081.50 (42"E) 1081.50 (42"W)
3	STA. 199+46.00, 34.00' RT. N 492498.42, E 2752174.53	III	X.XX'	X.XX'	X.XX'	1086.50 (15"W) 1085.85 (24"N) 1085.85 (24"S)
4	STA. 199+46.00, 4.00' LT. N 492496.64, E 2752136.57	I	X.XX'	X.XX'	X.XX'	1086.95 (15"E)
5	STA. 200+18.24, 34.00' RT. N 492570.58, E 2752171.16	III	X.XX'	X.XX'	X.XX'	1087.00 (15"W) 1086.25 (24"N) 1086.25 (24"S)
6	STA. 200+18.24, 4.00' LT. N 492568.80, E 2752133.20	I	X.XX'	X.XX'	X.XX'	1087.20 (15"E)
7	STA. 200+98.00, 34.00' RT. N 492650.25, E 2752167.43	III	X.XX'	X.XX'	X.XX'	1087.50 (15"W) 1086.75 (24"S)
8	STA. 200+98.00, 4.00' LT. N 492648.48, E 2752129.47	I	X.XX'	X.XX'	X.XX'	1087.70 (15"E)

196+00      197+00      198+00      199+00      200+00      201+00      202+00

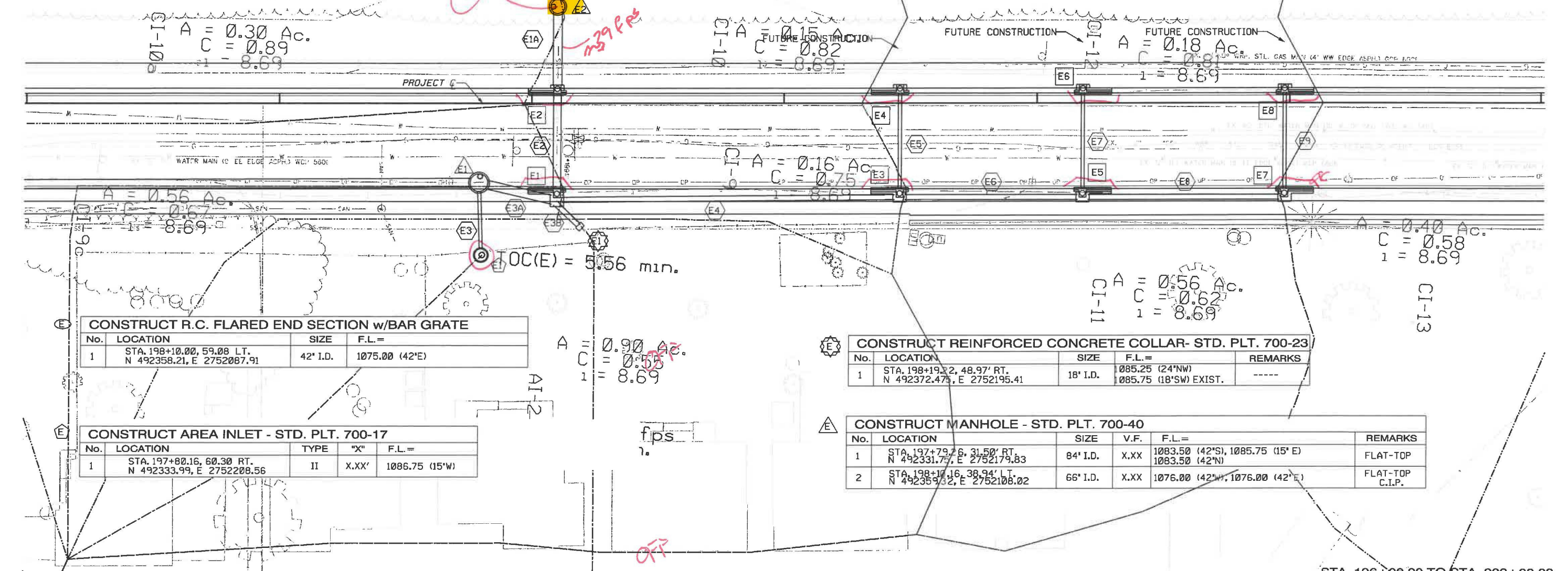

**E CONSTRUCT R.C. FLARED END SECTION w/BAR GRATE**

No.	LOCATION	SIZE	F.L.=
1	STA. 198+10.00, 59.08 LT. N 492358.21, E 2752087.91	42" I.D.	1075.00 (42"E)

**E CONSTRUCT REINFORCED CONCRETE COLLAR- STD. PLT. 700-23**

No.	LOCATION	SIZE	F.L.=	REMARKS
1	STA. 198+19.32, 48.97' RT. N 492372.47, E 2752195.41	18" I.D.	1085.25 (24"NW) 1085.75 (18"SW) EXIST.	---

**E CONSTRUCT AREA INLET - STD. PLT. 700-17**

No.	LOCATION	TYPE	"X"	F.L.=
1	STA. 197+80.16, 60.30 RT. N 492333.99, E 2752208.56	II	X.XX'	1086.75 (15"W)

**E CONSTRUCT MANHOLE - STD. PLT. 700-40**

No.	LOCATION	SIZE	V.F.	F.L.=	REMARKS
1	STA. 197+79.76, 31.50' RT. N 492331.77, E 2752179.83	84" I.D.	X.XX	1083.50 (42"S), 1085.75 (15"E) 1083.50 (42"N)	FLAT-TOP
2	STA. 198+10.16, 38.94' LT. N 492359.32, E 2752108.02	66" I.D.	X.XX	1076.00 (42"W), 1076.00 (42"E)	FLAT-TOP C.I.P.



STA. 196+00.00 TO STA. 202+00.00

## DRAINAGE



# 36TH STREET

*Lynnwood Dr.*



**CONSTRUCT REINFORCED CONCRETE PIPE**

No.	LOCATION	SIZE	REMARKS
1	C.I. NO. F1 TO C.I. NO. F2	15" X 90'	GR.=0.89%
2	C.I. NO. F2 TO M.H. NO. F1	18" X 94'	GR.=1.06%
3	C.I. NO. F3 TO C.I. NO. F2	15" X 42'	GR.=1.80%
4	M.H. NO. F1 TO M.H. NO. F2	24" X 122'	GR.=2.18%
5	C.I. NO. F4 TO C.I. NO. F5	15" X 101'	GR.=6.18%
6	C.I. NO. F6 TO C.I. NO. F7	15" X 61'	GR.=5.82%
7	C.I. NO. F5 TO C.I. NO. F7	18" X 36'	GR.=0.76%
8	C.I. NO. F7 TO M.H. NO. F1	24" X 38'	GR.=7.67%
9	A.I. NO. F1 TO M.H. NO. F2	30" X 18'	GR.=13.73%
10	M.H. NO. F2 TO M.H. NO. F3	36" X 82'	GR.=3.49%
11	M.H. NO. F3 TO F.E.S. NO. F1	36" X 35'	GR.=5.52%

**SAFL Baffle structure is highlighted in yellow.**

**CONSTRUCT CURB INLET - STD. PLT. 700+21**

No.	LOCATION	TYPE	"X"	"A"	"S"	F.L.=
1	STA. 202+15.00, 34.00' RT. N 492767.12, E 2752161.96	III	X.XX'	X.XX'	X.XX'	1089.05 (15°N)
2	STA. 203+05.00, 34.00' RT. N 492857.03, E 2752157.75	III	X.XX'	X.XX'	X.XX'	1088.25 (15°W) 1088.25 (15°S) 1088.00 (18°N)
3	STA. 203+05.00, 4.00' LT. N 492855.25, E 2752119.80	I	X.XX'	X.XX'	X.XX'	1089.00 (15°E)
4	STA. 801+74.87, 16.00' RT. N 492923.20, E 2752295.68	I	X.XX'	X.XX'	X.XX'	1096.50 (15°W)
5	STA. 800+74.50, 16.00' RT. N 492918.51, E 2752195.42	III	X.XX'	X.XX'	X.XX'	1090.30 (15°E) 1090.05 (18°N)
6	STA. 801+35.49, 16.00' LT. N 492953.32, E 2752254.85	I	X.XX'	X.XX'	X.XX'	1093.68 (18°W)
7	STA. 800+74.50, 16.00' LT. N 492950.47, E 2752193.93	III	X.XX'	X.XX'	X.XX'	1090.13 (15°E) 1089.78 (18°S) 1089.38 (24°W)

*215 fps*  
*W.D.F. or more*

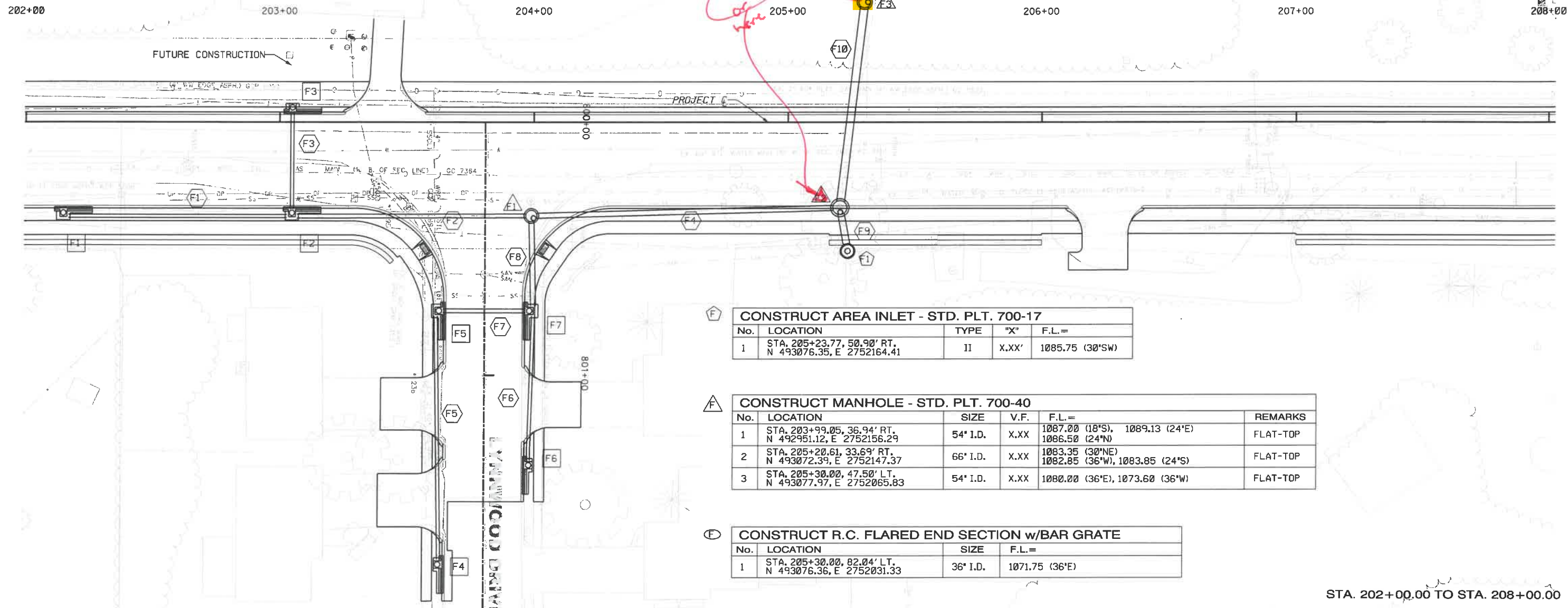

**CONSTRUCT AREA INLET - STD. PLT. 700-17**

No.	LOCATION	TYPE	"X"	F.L.=
1	STA. 205+23.77, 50.90' RT. N 493076.35, E 2752164.41	II	X.XX'	1085.75 (30°SW)

**CONSTRUCT MANHOLE - STD. PLT. 700-40**

No.	LOCATION	SIZE	V.F.	F.L.=	REMARKS
1	STA. 203+99.05, 36.94' RT. N 492951.12, E 2752156.29	54" I.D.	X.XX	1087.00 (18°S), 1089.13 (24°E) 1086.50 (24°N)	FLAT-TOP
2	STA. 205+20.61, 33.69' RT. N 493072.39, E 2752147.37	66" I.D.	X.XX	1083.35 (30°NE) 1082.85 (36°W), 1083.85 (24°S)	FLAT-TOP
3	STA. 205+30.00, 47.50' LT. N 493077.97, E 2752065.83	54" I.D.	X.XX	1080.00 (36°E), 1073.60 (36°W)	FLAT-TOP

**CONSTRUCT R.C. FLARED END SECTION w/BAR GRATE**

No.	LOCATION	SIZE	F.L.=
1	STA. 205+30.00, 82.04' LT. N 493076.36, E 2752031.33	36" I.D.	1071.75 (36°E)

STA. 202+00.00 TO STA. 208+00.00



**DRAINAGE**

**G CONSTRUCT REINFORCED CONCRETE PIPE**

No.	LOCATION	SIZE	REMARKS
1	C.I. NO. G2 TO M.H. NO. G1	15" X 21'	GR.=11.38%
2	C.I. NO. G1 TO M.H. NO. G1	15" X 21'	GR.=6.00%
3	M.H. NO. G1 TO M.H. NO. G2	18" X 160'	GR.=1.25%
4	C.I. NO. G3 TO M.H. NO. G2	18" X 21'	GR.=1.20%
5	C.C. NO. G1 TO C.I. NO. G3	18" X 55'	GR.=15.50%
6	M.H. NO. G2 TO M.H. NO. G3	24" X 147'	GR.=1.36%
7	A.I. NO. G1 TO C.I. NO. G4	30" X 27'	GR.=8.98%
8	C.I. NO. G4 TO M.H. NO. G3	30" X 21'	GR.=11.17%
9	C.I. NO. G5 TO M.H. NO. G3	15" X 21'	GR.=4.87%
10	M.H. NO. G3 TO M.H. NO. G7	36" X 49'	GR.=5.30%
10A	M.H. NO. G7 TO F.E.S. NO. G1	42" X 41'	GR.=2.45%
11	M.H. NO. G4 TO M.H. NO. G3	30" X 78'	GR.=0.95%
12	C.I. NO. G6 TO M.H. NO. G4	15" X 21'	GR.=12.24%
13	C.I. NO. G7 TO M.H. NO. G4	15" X 21'	GR.=4.39%
14	M.H. NO. G5 TO M.H. NO. G4	30" X 94'	GR.=1.10%
15	C.I. NO. G8 TO M.H. NO. G5	30" X 21'	GR.=1.10%
16	C.I. NO. G9 TO C.I. NO. G8	30" X 39'	GR.=1.08%
17	M.H. NO. G6 TO C.I. NO. G9	30" X 46'	GR.=1.08%
18	C.I. NO. G11 TO M.H. NO. G6	24" X 26'	GR.=5.08%
19	C.I. NO. G10 TO C.I. NO. G11	18" X 49'	GR.=4.56%

**36TH STREET**

*South of Leawood*

**G CONSTRUCT CURB INLET - STD. PLT. 700-21**

No.	LOCATION	TYPE	"X"	"A"	"S"	F.L.=
1	STA. 208+30.00, 34.00' RT. N 493381.45, E 2752133.22	I	X.XX'	X.XX'	X.XX'	1086.75 (15'W)
2	STA. 208+30.00, 4.00' LT. N 493379.68, E 2752095.26	I	X.XX'	X.XX'	X.XX'	1087.87 (15'E)
3	STA. 209+89.84, 34.00' RT. N 493541.12, E 2752125.75	I	X.XX'	X.XX'	X.XX'	1083.50 (18'SE) 1083.50 (18'W)
4	STA. 211+36.61, 34.00' RT. N 493687.73, E 2752118.89	I	X.XX'	X.XX'	X.XX'	1077.45 (30'E) 1085.28 (30'W)
5	STA. 211+36.61, 4.00' LT. N 493685.95, E 2752080.93	I	X.XX'	X.XX'	X.XX'	1085.00 (15'E)
6	STA. 212+14.21, 34.00' RT. N 493765.24, E 2752115.27	I	X.XX'	X.XX'	X.XX'	1084.95 (15'W)
7	STA. 212+14.21, 4.00' LT. N 493763.47, E 2752077.31	I	X.XX'	X.XX'	X.XX'	1083.30 (15'E)
8	STA. 213+08.00, 34.00' RT. N 493858.93, E 2752110.88	III	X.XX'	X.XX'	X.XX'	1082.33 (30'N) 1082.33 (30'W)
9	STA. 213+46.81, 34.00' RT. N 493897.70, E 2752109.07	III	X.XX'	X.XX'	X.XX'	1082.75 (30'N) 1082.75 (30'S)
10	STA. 1001+12.05, 16.00' RT. N 493950.79, E 2752184.73	III	X.XX'	X.XX'	X.XX'	1087.79 (18'W)
11	STA. 1000+62.53, 16.60' RT. N 493947.87, E 2752135.28	IV	X.XX'	X.XX'	X.XX'	1085.55 (18'NE) 1085.05 (24'W) 1085.55 (18'E)

**SAFL Baffle structure is highlighted in yellow.**

*W.Q.F.*

*17.3 fps*

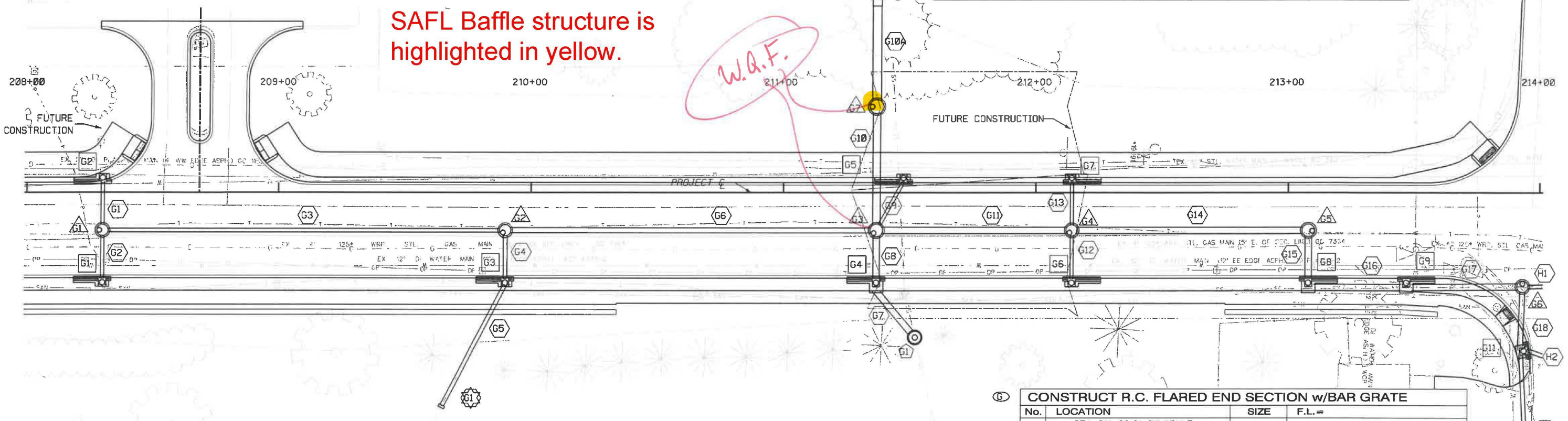

**G CONSTRUCT MANHOLE - STD. PLT. 700-40**

No.	LOCATION	SIZE	V.F.	F.L. =	REMARKS
1	STA. 208+30.00, 15.00' RT. N 493380.57, E 2752114.24	54" I.D.	X.XX	1085.25 (18'N), 1085.50 (15'E) 1085.50 (15'W)	FLAT-TOP
2	STA. 209+89.84, 15.00' RT. N 493540.24, E 2752106.77	54" I.D.	X.XX	1083.25 (18'S), 1082.75 (24'N) 1083.25 (18'E)	FLAT-TOP
3	STA. 211+36.61, 15.00' RT. N 493686.84, E 2752099.91	1	X.XX	1080.75 (24'S), 1075.01 (30'E) 1084.10 (15'W), 1080.33 (30'N) 1074.51 (36'W)	FLAT-TOP C.I.P.
4	STA. 212+14.21, 15.00' RT. N 493764.35, E 2752096.29	54" I.D.	X.XX	1081.07 (30'S), 1082.40 (15'E) 1082.40 (15'W), 1081.07 (30'N)	FLAT-TOP C.I.P.
5	STA. 213+08.00, 15.00' RT. N 493858.04, E 2752091.90	60" I.D.	X.XX	1082.10 (30'S) 1082.10 (30'E)	FLAT-TOP
6	STA. 213+93.19, 37.33' RT. N 493944.19, E 2752110.23	54" I.D.	X.XX	1084.25 (18'N), 1083.25 (30'S) 1083.75 (24'E)	FLAT-TOP
7	STA. 211+36.61, 34.22' LT. N 493684.54, E 2752050.74	66" I.D.	X.XX	1067.68 (42'W), 1071.90 (36'E)	FLAT-TOP C.I.P.

**G CONSTRUCT R.C. FLARED END SECTION w/BAR GRATE**

No.	LOCATION	SIZE	F.L. =
1	STA. 211+36.61, 75.25' LT. N 493682.62, E 2752009.76	42" I.D.	1066.70 (42'E)

**G CONSTRUCT REINFORCED CONCRETE COLLAR- STD. PLT. 700-23**

No.	LOCATION	SIZE	F.L. =	REMARKS
1	STA. 209+65.00, 84.66' RT N 493518.67, E 2752177.51	18" I.D.	1092.00 (18'NW) 1092.00 (18'SE) EXIST	

**G CONSTRUCT AREA INLET - STD. PLT. 700-17**

No.	LOCATION	TYPE	"X"	F.L. =
1	STA. 211+52.17, 57.57 RT. N 493704.37, E 2752141.71	II	X.XX'	1079.85 (30'W) 1080.35 (24'E) EXIST

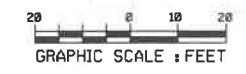

STA. 208+00.00 TO STA. 214+00.00

**DRAINAGE**

# 36TH STREET

CONSTRUCT MANHOLE - STD. PLT. 700-40					
No.	LOCATION	SIZE	V.F.	F.L.=	REMARKS
1	STA. 216+96.82, 6.36' RT. N 494246.03, E 2752064.88	60" I.D.	X.XX	1081.00 (30'SW), 1085.50 (24'NE) 1085.00 (30'SE)	FLAT-TOP C.I.P.
2	STA. 216+80.86, 37.08' RT. N 494231.57, E 2752096.34	54" I.D.	X.XX	1087.39 (18'S), 1086.39 (30'NW), 1086.39 (30'E) EXIST.	FLAT-TOP

CONSTRUCT R.C. FLARED END SECTION w/BAR GRATE			
No.	LOCATION	SIZE	F.L.=
1	STA. 216+78.22, 56.56' LT. N 494224.42, E 2752002.93	30" I.D.	1076.00 (30'NE)

SAFL Baffle structure is highlighted in yellow.

North of Leawood

25 fps

W.O.F.

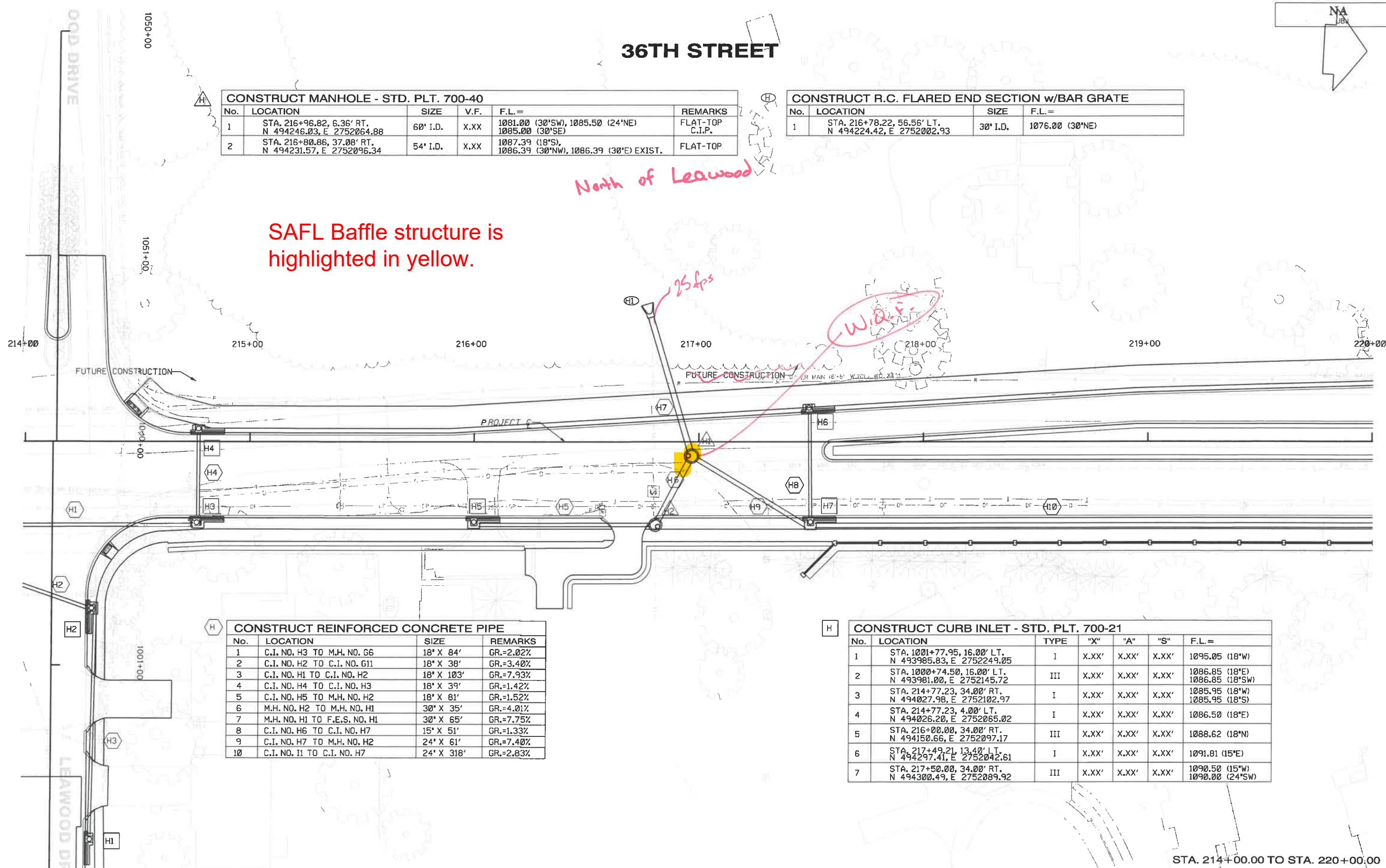

CONSTRUCT REINFORCED CONCRETE PIPE			
No.	LOCATION	SIZE	REMARKS
1	C.I. NO. H3 TO M.H. NO. G6	18" X 84'	GR.=2.02%
2	C.I. NO. H2 TO C.I. NO. G11	18" X 38'	GR.=3.40%
3	C.I. NO. H1 TO C.I. NO. H2	18" X 103'	GR.=7.93%
4	C.I. NO. H4 TO C.I. NO. H3	18" X 39'	GR.=1.42%
5	C.I. NO. H5 TO M.H. NO. H2	18" X 81'	GR.=1.52%
6	M.H. NO. H2 TO M.H. NO. H1	30" X 35'	GR.=4.01%
7	M.H. NO. H1 TO F.E.S. NO. H1	30" X 65'	GR.=7.75%
8	C.I. NO. H6 TO C.I. NO. H7	15" X 51'	GR.=1.33%
9	C.I. NO. H7 TO M.H. NO. H2	24" X 61'	GR.=7.40%
10	C.I. NO. I1 TO C.I. NO. H7	24" X 318'	GR.=2.83%

CONSTRUCT CURB INLET - STD. PLT. 700-21							
No.	LOCATION	TYPE	"X"	"A"	"S"	F.L.=	
1	STA. 100+77.95, 16.00' LT. N 493985.83, E 2752249.05	I	X.XX'	X.XX'	X.XX'	1095.05 (18"W)	
2	STA. 100+74.50, 16.00' LT. N 493981.00, E 2752145.72	III	X.XX'	X.XX'	X.XX'	1086.85 (18"E) 1086.85 (18"SW)	
3	STA. 214+77.23, 34.00' RT. N 494027.98, E 2752102.97	I	X.XX'	X.XX'	X.XX'	1085.95 (18"W) 1085.95 (18"S)	
4	STA. 214+77.23, 4.00' LT. N 494026.20, E 2752065.02	I	X.XX'	X.XX'	X.XX'	1086.50 (18"E)	
5	STA. 216+00.00, 34.00' RT. N 494150.66, E 2752097.17	III	X.XX'	X.XX'	X.XX'	1088.62 (18"N)	
6	STA. 217+49.21, 13.40' LT. N 494297.41, E 2752042.61	I	X.XX'	X.XX'	X.XX'	1091.81 (15"E)	
7	STA. 217+50.00, 34.00' RT. N 494300.49, E 2752089.92	III	X.XX'	X.XX'	X.XX'	1090.50 (15"W) 1090.00 (24"SW)	



STA. 214+00.00 TO STA. 220+00.00

**DRAINAGE**

# 36TH STREET

**CONSTRUCT REINFORCED CONCRETE PIPE**

No.	LOCATION	SIZE	REMARKS
1	C.I. NO. 14 TO C.I. NO 12	15" X 29"	GR.=0.70%
2	C.I. NO. 15 TO C.I. NO 13	15" X 29"	GR.=2.37%
3	C.I. NO. 13 TO C.I. NO 12	18" X 20"	GR.=10.50%
4	C.I. NO. 12 TO M.H. NO 11	18" X 37"	GR.=3.47%
5	M.H. NO. 11 TO C.I. NO 11	18" X 239"	GR.=1.96%

**CONSTRUCT CURB INLET - STD. PLT. 700-21**

No.	LOCATION	TYPE	"X"	"A"	"S"	F.L.=
1	STA. 220+68.00, 34.00' RT. N 494618.11, E 2752074.55	III	X.XX'	X.XX'	X.XX'	1099.00 (24'S)
2	STA. 1100+74.50, 12.50' RT. N 494860.79, E 2752103.35	III	X.XX'	X.XX'	X.XX'	1106.25 (15'N) 1105.00 (18'W) 1105.00 (18'E)
3	STA. 1100+94.50, 12.50' RT. N 494861.75, E 2752123.33	III	X.XX'	X.XX'	X.XX'	1107.10 (18'W) 1107.10 (15'N)
4	STA. 1100+74.50, 12.50' LT. N 494885.76, E 2752102.14	I	X.XX'	X.XX'	X.XX'	1106.05 (15'S)
5	STA. 1100+94.50, 12.50' LT. N 494886.72, E 2752122.12	I	X.XX'	X.XX'	X.XX'	1107.78 (15'S)
6	STA. 226+00.91, 4.00' LT. N 495147.66, E 2752010.88	I	X.XX'	X.XX'	X.XX'	1103.55 (15'N)

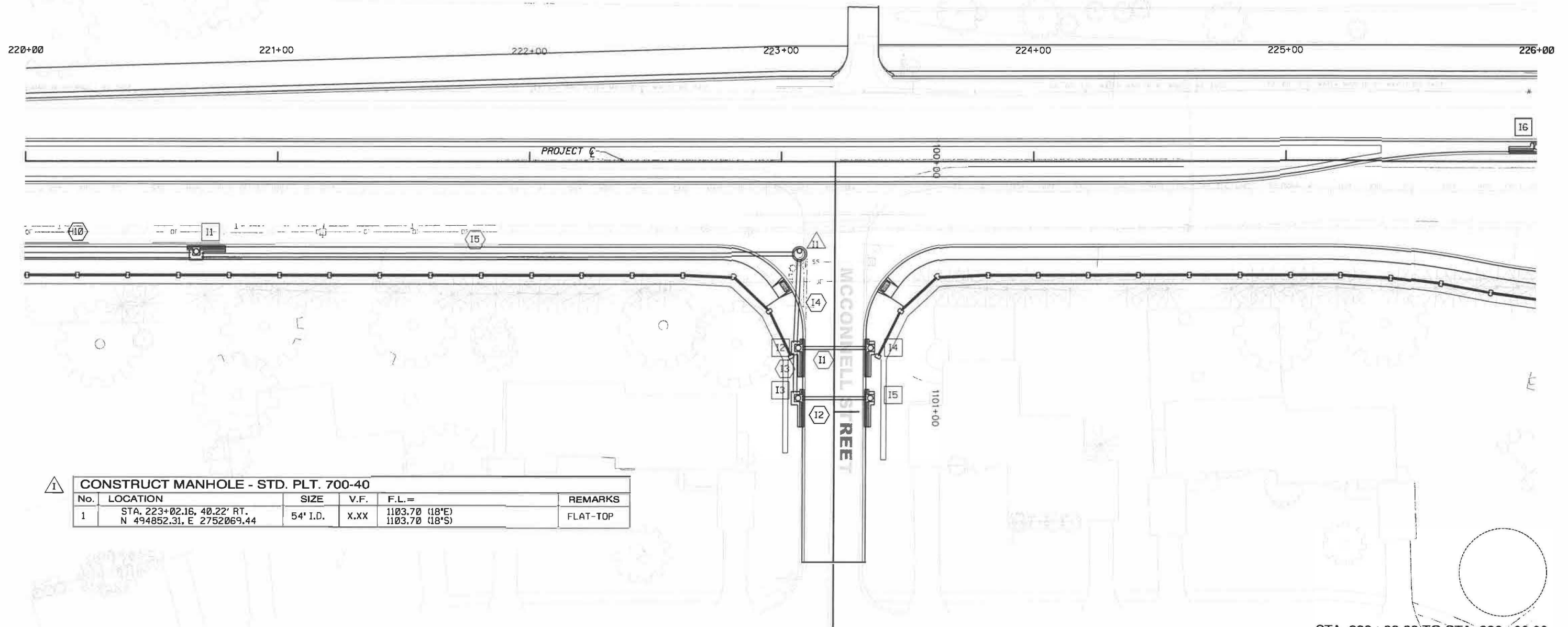

**CONSTRUCT MANHOLE - STD. PLT. 700-40**

No.	LOCATION	SIZE	V.F.	F.L.=	REMARKS
1	STA. 223+02.16, 40.22' RT. N 494852.31, E 2752069.44	54' I.D.	X.XX	1103.70 (18'E) 1103.70 (18'S)	FLAT-TOP

STA. 220+00.00 TO STA. 226+00.00



**DRAINAGE**



**CONSTRUCT REINFORCED CONCRETE PIPE**

No.	LOCATION	SIZE	REMARKS
1	C.I. NO. I6 TO C.I. NO J2	15" X 200'	GR.=3.70%
2	C.I. NO. J1 TO TAP NO. J1	15" X 21'	GR.=9.83%
3	A.I. NO. J1 TO M.H. NO J1	30" X 67'	GR.=0.78%
4	M.H. NO. J1 TO C.I. NO. J2	36" X 20'	GR.=0.55%
5	C.I. NO. J2 TO F.E.S. NO J1	36" X 79'	GR.=0.50%
6	M.H. NO. S1 TO C.I. NO J4	18" X 112'	GR.=3.21%
7	C.I. NO. J3 TO C.I. NO J4	15" X 49'	GR.=4.39%
8	C.I. NO. J4 TO A.I. NO J2	24" X 55'	GR.=1.19%
9	A.I. NO. J2 TO M.H. NO J2	24" X 53'	GR.=0.65%
10	C.I. NO. J6 TO C.I. NO J5	15" X 43'	GR.=1.03%
11	C.I. NO. J5 TO M.H. NO J2	15" X 32'	GR.=2.73%
12	M.H. NO. J2 TO M.H. NO. J3	30" X 80'	GR.=0.51%
13	C.I. NO. J8 TO C.I. NO. J7	15" X 42'	GR.=2.64%
14	C.I. NO. J7 TO M.H. NO J3	15" X 31'	GR.=4.36%
15	M.H. NO. J3 TO M.H. NO. J4	30" X 87'	GR.=1.15%
16	C.I. NO. J9 TO M.H. NO J4	15" X 31'	GR.=10.84%
17	M.H. NO. J4 TO C.I. NO. K1	30" X 133'	GR.=1.50%

**TAP REINFORCED CONCRETE PIPE**

No.	LOCATION	F.L. =
1	STA. 228+01.13, 39.31' LT N 495346.85, E 2751965.89	1096.44 (15' S)

**CONSTRUCT CURB INLET - STD. PLT. 700-21**

No.	LOCATION	TYPE	"X"	"A"	"S"	F.L. =
1	STA. 227+81.03, 36.74' LT. N 495326.90, E 2752969.42	I	X.XX'	X.XX'	X.XX'	1098.49 (15'N)
2	STA. 227+99.81, 4.00' LT. N 495347.24, E 2752001.22	II	X.XX'	X.XX'	X.XX'	1096.15 (15'S) 1095.27 (36'W) 1095.27 (36'E)
3	STA. 1200+75.50, 8.00' RT. N 495415.72, E 2752077.50	I	X.XX'	X.XX'	X.XX'	1089.79 (15'NE)
4	STA. 1200+95.75, 36.31' LT. N 495460.95, E 2752095.59	III	X.XX'	X.XX'	X.XX'	1096.65 (15'SW), 1096.40 (18'E) 1095.90 (24'NW)
5	STA. 229+98.58, 8.00' RT. N 495546.35, E 2752003.60	I	X.XX'	X.XX'	X.XX'	1094.77 (15'W) 1094.77 (15'SE)
6	STA. 229+98.76, 34.93' LT. N 495544.46, E 2751960.72	I	X.XX'	X.XX'	X.XX'	1095.21 (15'E)
7	STA. 230+79.00, 8.00' RT. N 495626.68, E 2751194.72	I	X.XX'	X.XX'	X.XX'	1094.86 (15'W) 1094.86 (15'E)
8	STA. 230+79.00, 34.00' LT. N 495624.65, E 2751957.77	I	X.XX'	X.XX'	X.XX'	1095.97 (15'E)
9	STA. 231+66.00, 8.00' RT. N 495713.57, E 2751995.51	I	X.XX'	X.XX'	X.XX'	1095.88 (15'E)

**CONSTRUCT AREA INLET - STD. PLT. 700-17**

No.	LOCATION	TYPE	"X"	F.L. =
1	STA. 228+10.00, 79.97' RT. N 495361.47, E 2752084.60	II	X.XX'	1096.40 (30'W) 1096.90 (24'SE) EXIST
2	STA. 229+50.05, 58.05' RT. N 495500.29, E 2752055.94	II	X.XX'	1095.25 (24'SE) 1094.75 (24'NW)

**CONSTRUCT R.C. FLARED END SECTION w/BAR GRATE**

No.	LOCATION	SIZE	F.L. =
1	STA. 1256+10.69, 64.59' RT N 495349.35, E 2751925.92	36" I.D.	1094.89 (36' E)

**CONSTRUCT MANHOLE - STD. PLT. 700-40**

No.	LOCATION	SIZE	V.F.	F.L. =	REMARKS
1	STA. 227+98.13, 14.00' RT. N 495346.43, E 2752019.29	54" I.O.	X.XX	1095.88 (30'E), 1095.38 (36'W)	FLAT-TOP C.I.P.
2	STA. 229+98.58, 37.63' RT. N 495547.78, E 2752033.20	54" I.O.	X.XX	1094.41 (24'SE), 1093.91 (15'W) 1093.91 (30'N)	FLAT-TOP
3	STA. 230+79.00, 37.33' RT. N 495528.10, E 2752029.02	54" I.D.	X.XX	1093.50 (30'S), 1093.50 (15'W) 1093.91 (30'N)	FLAT-TOP
4	STA. 231+66.00, 37.33' RT. N 495714.99, E 2752024.81	54" I.D.	X.XX	1092.50 (30'S), 1092.50 (15'W) 1092.50 (30'N)	FLAT-TOP

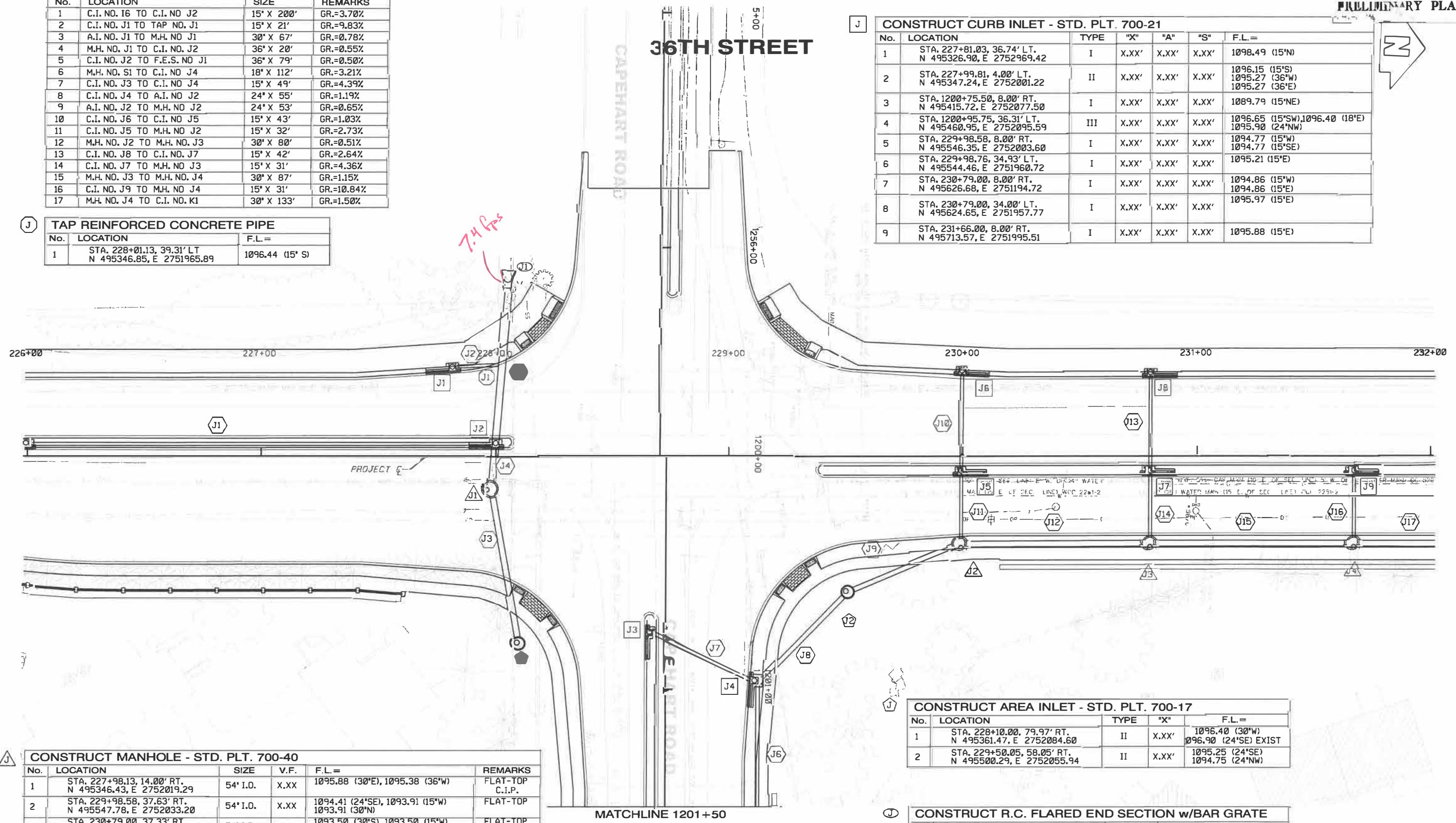

DIVISION

zturak

4/2/2018

1:40-0259

STA. 226+00.00 TO STA. 232+00.00



**DRAINAGE**

### 36TH STREET



**CONSTRUCT REINFORCED CONCRETE PIPE**

No.	LOCATION	SIZE	REMARKS
1	C.I. NO. K1 TO M.H. NO. K1	30" X 78'	GR.=7.70%
2	M.H. NO. K1 TO F.E.S. NO. K1	36" X 71'	GR.=3.53%
3	C.I. NO. K2 TO C.I. NO. K1	15" X 265'	GR.=5.14%
4	C.I. NO. K3 TO C.I. NO. K2	15" X 72'	GR.=0.63%

**CONSTRUCT CURB INLET - STD. PLT. 700-21**

No.	LOCATION	TYPE	"X"	"A"	"S"	F.L.=
1	STA. 232+99.38, 34.00' RT. N 495848.06, E 2752015.04	III	X.XX'	X.XX'	X.XX'	1090.50 (30"W) 1090.50 (30"S) 1091.75 (15"N) 1095.21 (30"E) EXIST)
2	STA. 235+64.60, 34.00' RT. N 496112.97, E 2752002.22	I	X.XX'	X.XX'	X.XX'	1105.39 (15"W) 1105.39 (15"S)
3	STA. 235+64.59, 34.00' LT. N 496109.66, E 2751934.30	I	X.XX'	X.XX'	X.XX'	1105.84 (15"E)

SAFL Baffle structure is highlighted in yellow.

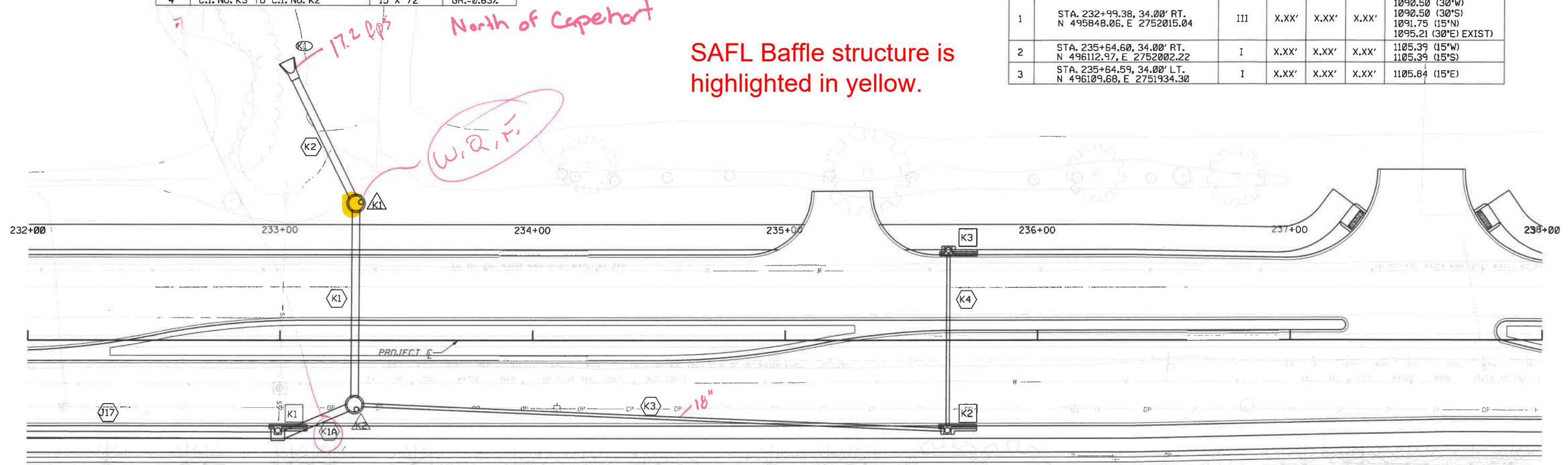

**CONSTRUCT MANHOLE - STD. PLT. 700-40**

No.	LOCATION	SIZE	V.F.	F.L.=	REMARKS
1	STA. 232+99.28, 42.08' LT. N 491844.25, E 2751939.05	54" I.D.	X.XX	1084.50 (30"E), 1084.00 (36"W)	FLAT-TOP C.I.P.

**CONSTRUCT R.C. FLARED END SECTION w/BAR GRATE**

No.	LOCATION	SIZE	F.L.=
1	STA. 232+99.36, 113.81' LT. N 495840.89, E 2752867.40	36" I.D.	1081.50 (36"E)

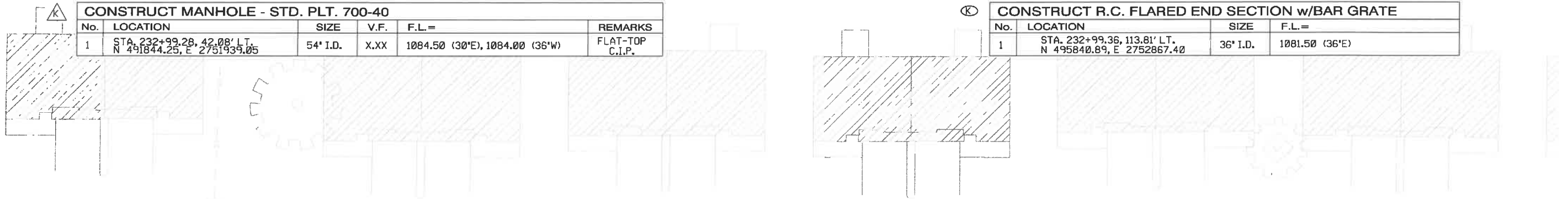

# 36TH STREET

ROADWAY DESIGN DIVISION

CONSTRUCT REINFORCED CONCRETE PIPE			
No.	LOCATION	SIZE	REMARKS
1	A.I. NO. L1 TO C.I. NO. L1	18" X 74'	GR.=3.19%
2	C.I. NO. L2 TO C.I. NO. L1	15" X 67'	GR.=0.52%
3	C.I. NO. L1 TO C.I. NO. M2	18" X 307'	GR.=1.60%

CONSTRUCT CURB INLET - STD. PLT. 700-21						
No.	LOCATION	TYPE	"X"	"A"	"S"	F.L.=
1	STA. 243+08.79, 31.00' RT. N 496855.80, E. 2751974.01	III	X.XX'	X.XX'	X.XX'	1107.65 (18°SE) 1107.90 (15°W) 1107.65 (18°N)
2	STA. 243+08.79, 34.92' LT. N 496854.26, E. 2751911.03	I	X.XX'	X.XX'	X.XX'	1108.25 (15°E)

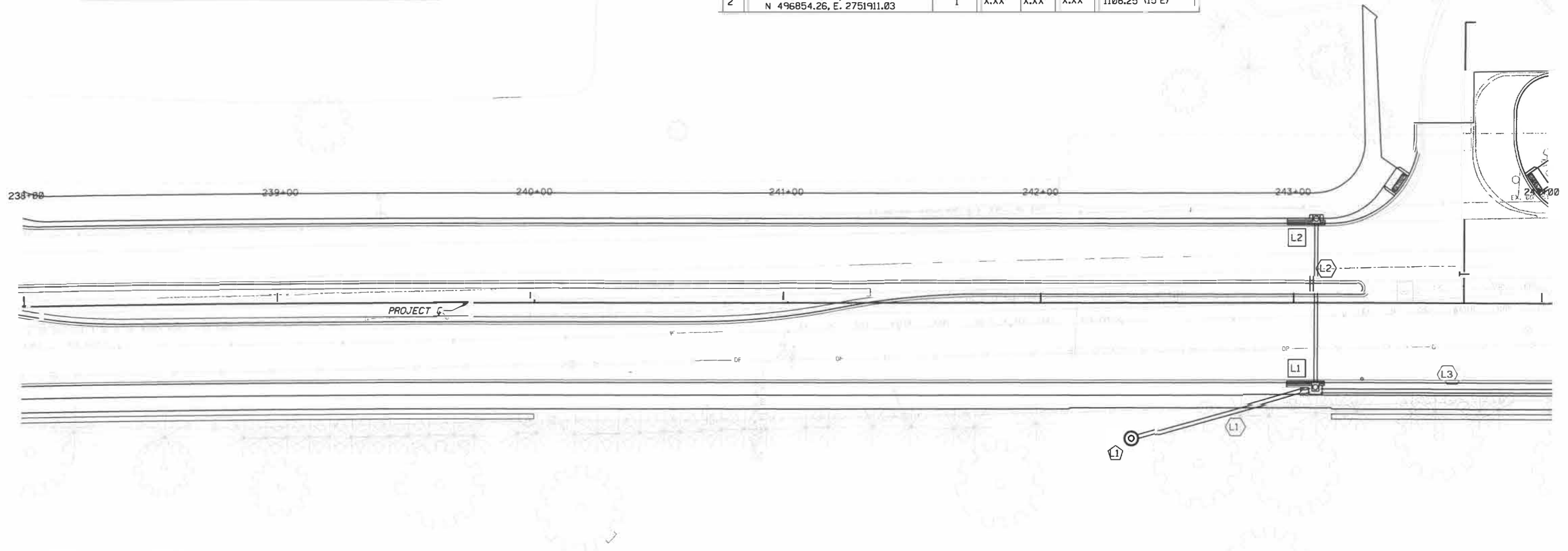

CONSTRUCT AREA INLET - STD. PLT. 700-17				
No.	LOCATION	TYPE	"X"	F.L.=
1	STA. 242+38.00, 54.00' RT. N 496785.57, E. 2751998.23	II	X.XX'	1110.00 (18°NW)



STA. 238+00.00 TO STA. 244+00.00

**DRAINAGE**

# 36TH STREET

## CONSTRUCT REINFORCE CONCRETE PIPE

No.	LOCATION	SIZE	REMARKS
1	C.I. NO. M1 TO C.I. NO. M2	15" X 67'	GR.=0.52%
2	C.I. NO. M2 TO C.I. NO. M3	24" X 220'	GR.=1.59%
3	C.I. NO. M4 TO C.I. NO. M3	15" X 67'	GR.=0.52%
4	C.I. NO. M3 TO C.I. NO. M5	24" X 161'	GR.=1.58%

## CONSTRUCT CURB INLET - STD. PLT. 700-21

No.	LOCATION	TYPE	"X"	"A"	"S"	F.L.=
1	STA. 246+15.00, 31.50' LT. N 497160.02, E. 2751903.00	I	X.XX'	X.XX'	X.XX'	1103.35 (15'E)
2	STA. 246+15.00, 31.50' RT. N 497162.23, E. 2751965.96	III	X.XX'	X.XX'	X.XX'	1103.00 (15'W) 1102.75 (18'S) 1102.25 (24'N)
3	STA. 248+34.16, 31.50' RT. N 497381.65, E. 2751956.07	III	X.XX'	X.XX'	X.XX'	1099.50 (15'W) 1098.75 (24'S) 1098.75 (24'N)
4	STA. 248+34.16, 31.50' LT. N 497378.48, E. 2751893.15	I	X.XX'	X.XX'	X.XX'	1199.85 (15'E)
5	STA. 249+95.21, 31.50' RT. N 497542.50, E. 2751947.96	III	X.XX'	X.XX'	X.XX'	1196.20 (24'S) 1196.20 (24'N)

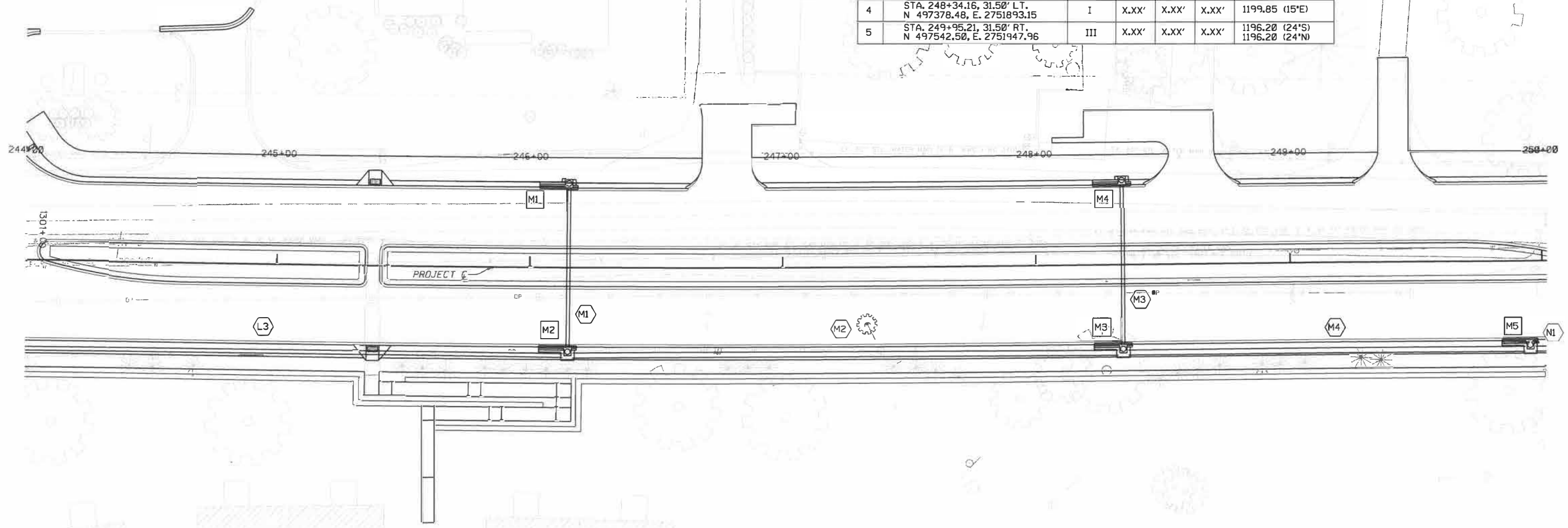

STA. 244+00.00 TO STA. 250+00.00

## DRAINAGE



zturek

4/2/2018

1-10.0001



### 36TH STREET

Lockbourne Dr.

**CONSTRUCT REINFORCED CONCRETE PIPE**

No.	LOCATION	SIZE	REMARKS
1	C.I. NO. M5 TO M.H. NO. N1	24" X 37"	GR.=9.95%
2	C.I. NO. N1 TO M.H. NO. N1	30" X 37"	GR.=8.86%
3	M.H. NO. N1 TO R.C.C. NO. N1	30" X 82"	GR.=7.29%
3A	R.C.C. NO. N1 TO F.E.S. NO. N1	30" X 42"	GR.=4.51%
4	C.I. NO. N2 TO C.I. NO. N1	15" X 39"	GR.=2.46%
5	C.I. NO. N3 TO M.H. NO. N1	24" X 100'	GR.=1.60%
6	C.I. NO. N4 TO C.I. NO. N3	15" X 67"	GR.=1.65%
7	C.I. NO. N5 TO C.I. NO. N3	18" X 74"	GR.=0.54%
8	C.I. NO. N6 TO C.I. NO. N5	18" X 67"	GR.=1.05%
9	C.I. NO. N7 TO C.I. NO. N5	18" X 71"	GR.=0.49%
10	C.I. NO. N8 TO C.I. NO. N7	15" X 67"	GR.=0.57%
11	C.I. NO. N9 TO C.I. NO. N10	15" X 67"	GR.=0.51%
12	C.I. NO. N10 TO M.H. NO. N2	18" X 60'	GR.=6.72%
13	M.H. NO. N2 TO R.C.C. NO. N2	24" X 30'	GR.=33.03%
13A	R.C.C. NO. N2 TO F.E.S. NO. N2	24" X 23'	GR.=1.95%
14	C.I. NO. N11 TO M.H. NO. N2	24" X 87"	GR.=1.27%
15	C.I. NO. O1 TO C.I. NO. N11	15" X 56'	GR.=3.12%

**CONSTRUCT R.C. FLARED END SECTION w/BAR GRATE**

No.	LOCATION	SIZE	F.L.=
1	STA. 250+39.23, 89.41 LT. N 497580.37, E. 2751824.99	30" I.D.	1084.10 (30"E)
2	STA. 255+55.00, 97.55 LT. N 498095.07, E. 2751790.87	24" I.D.	1081.80 (24"E)

SAFL Baffle structure will be added at location highlighted in yellow.

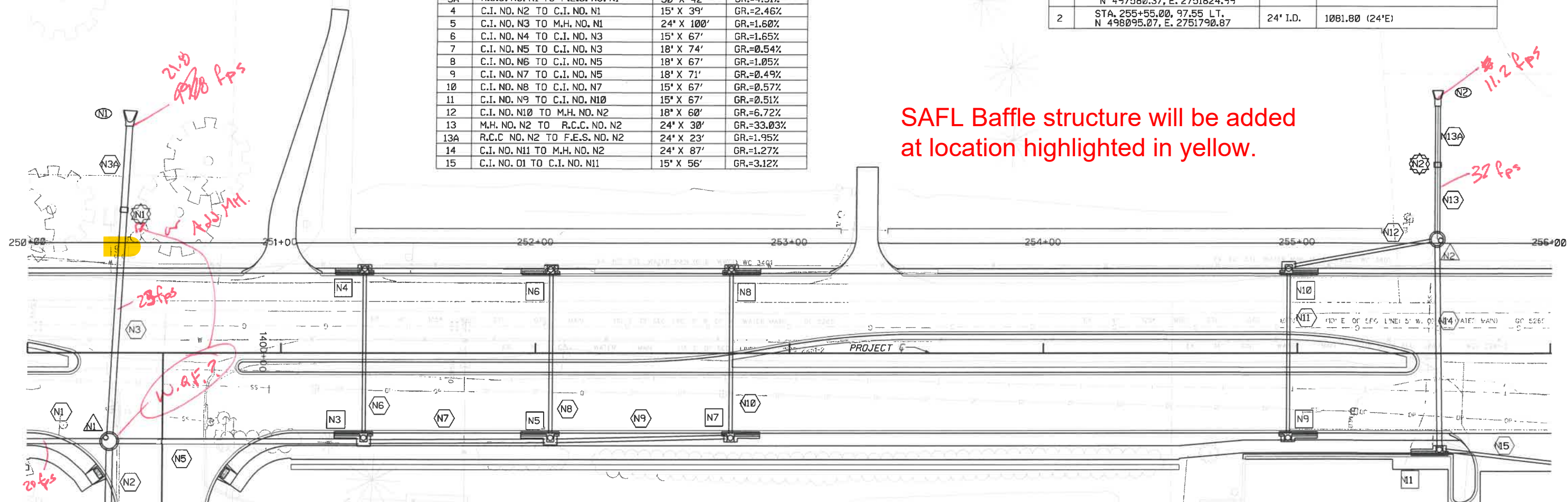

**CONSTRUCT CURB INLET - STD. PLT. 700-21**

No.	LOCATION	TYPE	"X"	"A"	"S"	F.L.=
1	STA. 1400+72.07, 17.42' RT. N 497585.00, E. 2751986.43	III	X.XX'	X.XX'	X.XX'	1096.30 (15"N) 1095.30 (30"W)
2	STA. 1400+72.02, 17.50' LT. N 497619.95, E. 2751984.63	I	X.XX'	X.XX'	X.XX'	1097.25 (15"S)
3	STA. 251+32.46, 31.50' RT. N 497679.57, E. 2751941.04	III	X.XX'	X.XX'	X.XX'	1094.85 (15"W) 1094.60 (18"N) 1094.10 (24"S)
4	STA. 251+32.46, 31.50' LT. N 497676.40, E. 2751878.12	I	X.XX'	X.XX'	X.XX'	1097.25 (15"E)
5	STA. 252+06.00, 31.50' RT. N 497753.02, E. 2751937.34	III	X.XX'	X.XX'	X.XX'	1095.25 (15"W) 1095.00 (18"N) 1095.00 (18"S)
6	STA. 252+06.00, 31.50' LT. N 497749.85, E. 2751874.42	I	X.XX'	X.XX'	X.XX'	1095.95 (15"E)
7	STA. 252+77.00, 31.50' RT. N 497823.93, E. 2751933.76	I	X.XX'	X.XX'	X.XX'	1095.60 (15"W) 1095.35 (18"S)
8	STA. 252+77.00, 31.50' LT. N 497820.75, E. 2751870.84	I	X.XX'	X.XX'	X.XX'	1095.98 (15"E)
9	STA. 254+96.45, 31.50' RT. N 498043.10, E. 2751922.70	I	X.XX'	X.XX'	X.XX'	1097.10 (15"W)
10	STA. 254+96.45, 31.50' LT. N 498039.93, E. 2751859.78	III	X.XX'	X.XX'	X.XX'	1096.76 (15"E) 1096.51 (18"NW)
11	STA. 255+49.00, 43.50' RT. N 498096.19, E. 2751932.04	I	X.XX'	X.XX'	X.XX'	1093.85 (15"N) 1093.10 (24"W) 1093.60 (18"E) EXIST.

**CONSTRUCT MANHOLE - STD. PLT. 700-40**

No.	LOCATION	SIZE	V.F.	F.L.=	REMARKS
1	STA. 250+32.38, 34.83' RT. N 497579.79, E. 2751949.41	60" I.D.	X.XX	1092.50 (24"S), 1092.50 (24"N) 1092.00 (30"E), 1092.00 (30"W)	FLAT-TOP
2	STA. 255+55.00, 45.00' LT. N 498097.72, E. 2751843.35	60" I.D.	X.XX	1092.00 (24"W), 1092.00 (24"E) 1092.50 (18"SE)	FLAT-TOP

**CONSTRUCT REINFORCED CONCRETE COLLAR- STD. PLT. 700-23**

No.	LOCATION	SIZE	F.L.=	REMARKS
1	STA. 250+37.41, 56.46' LT. N 497580.22, E. 2751857.99	30" I.D.	1086.00 (30"E), 1086.00 (30"W)	SUBSIDIARY ITEM
2	STA. 255+55.00, 74.41' LT. N 498096.24, E. 2751813.98	24" I.D.	1082.25 (24"E), 1082.25 (24"W)	SUBSIDIARY ITEM

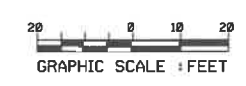

STA. 250+00.00 TO STA. 256+00.00

## DRAINAGE

# 36TH STREET

**CONSTRUCT REINFORCED CONCRETE PIPE**

No.	LOCATION	SIZE	REMARKS
1	C.I. NO. 02 TO C.I. NO. 03	15" X 67'	GR.=0.52%
2	C.I. NO. 03 TO C.I. NO. 01	15" X 136'	GR.=1.32%
3	C.I. NO. 04 TO C.I. NO. 05	15" X 67'	GR.=0.63%
4	C.I. NO. 05 TO M.H. NO. 01	18" X 121'	GR.=1.66%
5	M.H. NO. 01 TO R.C.C. NO. 01	24" X 55'	GR.=24.63%
5A	R.C.C. NO. 01 TO F.E.S. NO. 01	24" X 20'	GR.=2.78%
6	C.I. NO. 06 TO M.H. NO. 01	24" X 68'	GR.=2.19%
7	C.I. NO. 08 TO C.I. NO. 06	24" X 62'	GR.=2.17%
8	C.I. NO. 07 TO C.I. NO. 08	18" X 20'	GR.=5.09%
9	C.I. NO. 11 TO C.I. NO. 08	24" X 50'	GR.=2.21%
10	C.I. NO. 10 TO C.I. NO. 11	24" X 23'	GR.=1.07%
11	C.I. NO. 09 TO C.I. NO. 10	18" X 23'	GR.=2.23%

**CONSTRUCT CURB INLET - STD. PLT. 700-21**

No.	LOCATION	TYPE	"X"	"A"	"S"	F.L.=
1	STA. 256+04.90, 46.43' RT. N 498152.32, E. 2751932.09	III	X.XX'	X.XX'	X.XX'	1095.60 (15'S) 1095.60 (15'NW)
2	STA. 257+40.00, 31.50' LT. N 498282.56, E. 2751846.13	I	X.XX'	X.XX'	X.XX'	1097.95 (15'E)
3	STA. 257+40.00, 31.50' RT. N 498283.79, E. 2751908.99	I	X.XX'	X.XX'	X.XX'	1097.40 (15'W) 1097.40 (15'SE)
4	STA. 259+55.51, 31.50' RT. N 498501.98, E. 2751893.04	I	X.XX'	X.XX'	X.XX'	1099.47 (15'W)
5	STA. 259+55.51, 31.50' LT. N 498497.22, E. 2751830.22	III	X.XX'	X.XX'	X.XX'	1099.05 (15'E) 1098.80 (18'N)
6	STA. 260+03.83, 31.50' RT. N 498629.93, E. 2751883.35	I	X.XX'	X.XX'	X.XX'	1097.80 (24'NE) 1097.80 (24'W)
7	STA. 1500+97.43, 23.00' RT. N 498681.33, E. 2751941.98	III	X.XX'	X.XX'	X.XX'	1100.71 (18'W)
8	STA. 1500+75.77, 23.00' RT. N 498682.07, E. 2751921.99	III	X.XX'	X.XX'	X.XX'	1099.70 (18'E) 1099.15 (24'N) 1099.15 (24'SW)
9	STA. 1501+18.25, 23.14' LT. N 498724.93, E. 2751967.63	III	X.XX'	X.XX'	X.XX'	1101.75 (18'W)
10	STA. 1500+97.43, 23.00' LT. N 498727.21, E. 2751945.33	III	X.XX'	X.XX'	X.XX'	1101.25 (18'E) 1100.75 (24'W)
11	STA. 1500+75.76, 23.00' LT. N 498728.07, E. 2751922.02	III	X.XX'	X.XX'	X.XX'	1100.50 (24'E) 1100.25 (24'S)

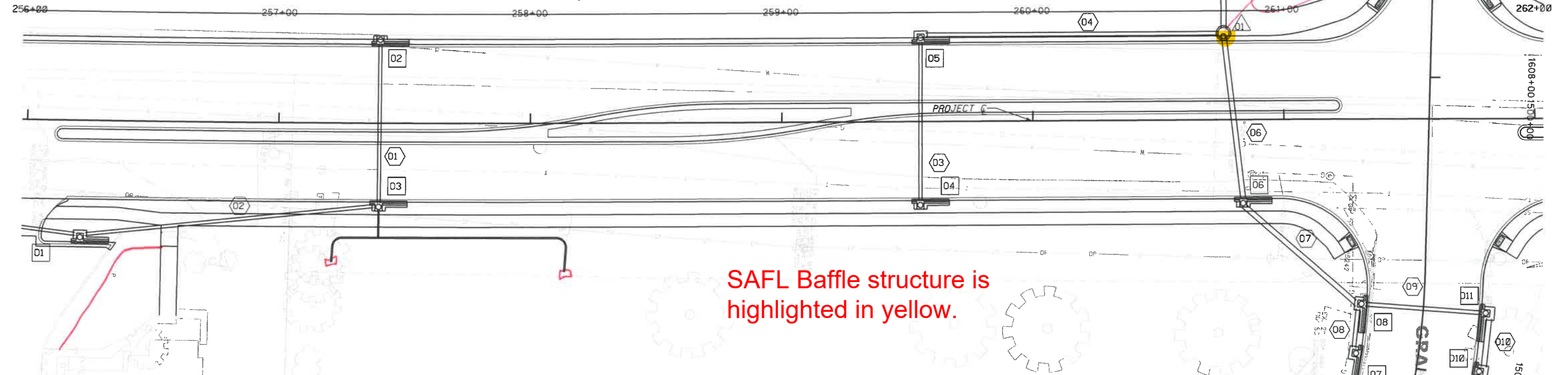
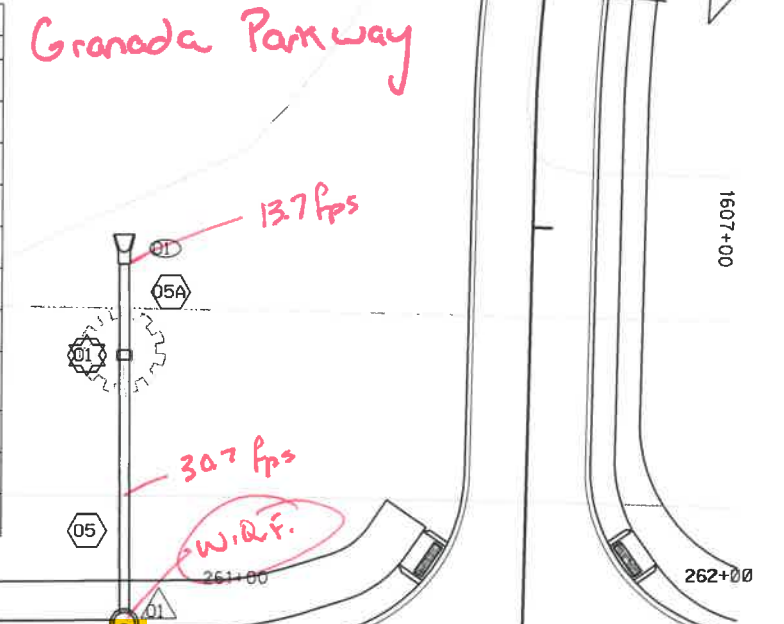

SAFL Baffle structure is highlighted in yellow.

**CONSTRUCT MANHOLE - STD. PLT. 700-40**

No.	LOCATION	SIZE	V.F.	F.L.=	REMARKS
1	STA. 260+76.00, 34.58' LT. N 498617.13, E. 2751818.05	54" I.D.	X.XX	1096.80 (18'S), 1096.30 (24'E) 1096.30 (24'W)	FLAT-TOP

**CONSTRUCT R.C. FLARED END SECTION w/BAR GRATE**

No.	LOCATION	SIZE	F.L.=
1	STA. 260+76.00, 109.40' LT. N 498611.48, E. 2751743.45	24" I.D.	1082.20 (24'E)

**CONSTRUCT REINFORCED CONCRETE COLLAR- STD. PLT. 700-23**

No.	LOCATION	SIZE	F.L.=	REMARKS
1	STA. 260+76.00, 90.42' LT. N 498612.91, E. 2751762.37	24" I.D.	1082.75 (24'E) 1082.75 (24'W)	SUBSIDIARY ITEM

# 36TH STREET

**CONSTRUCT REINFORCED CONCRETE PIPE**

No.	LOCATION	SIZE	REMARKS
1	C.I. NO. P1 TO F.E.S. NO. P1	18" X 58'	GR.=3.38%
2	C.I. NO. P2 TO C.I. NO. P1	18" X 67'	GR.=5.62%
3	C.I. NO. Q2 TO C.I. NO. P1	18" X 203'	GR.=0.76%
4	A.I. NO. P1 TO C.I. NO. P2	18" X 25'	GR.=0.61%

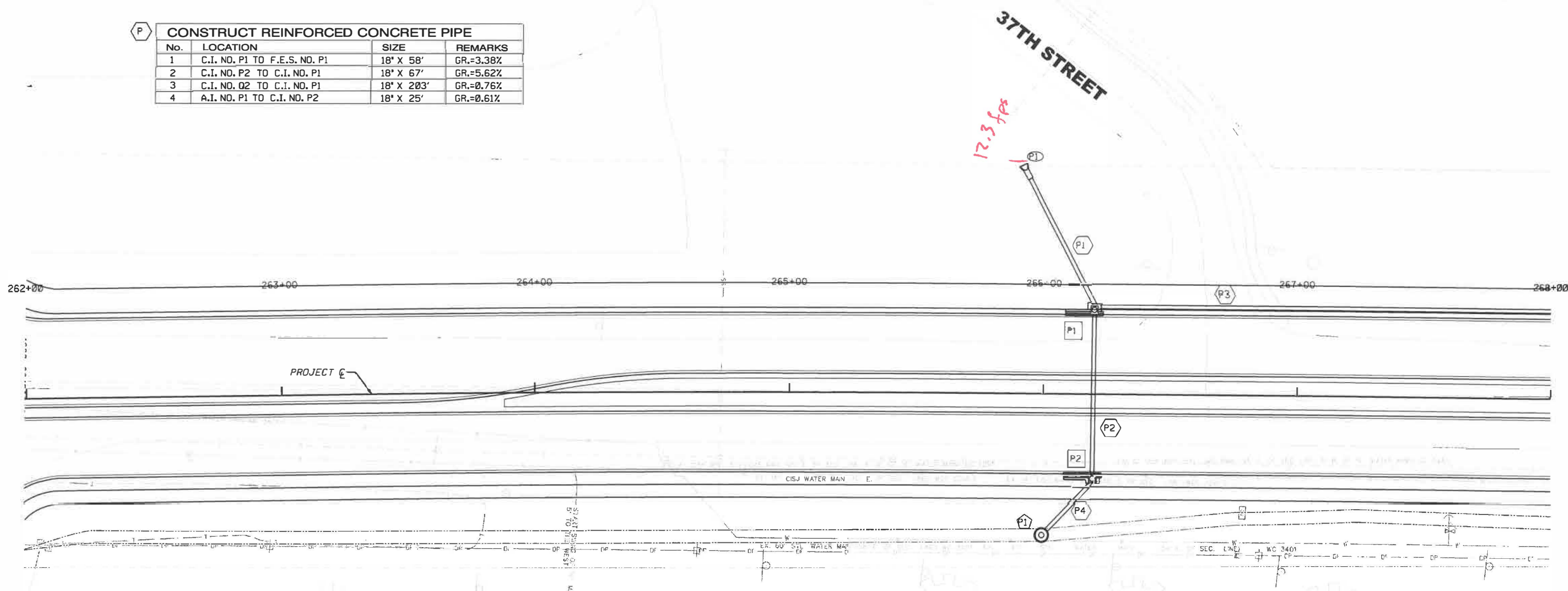

**CONSTRUCT AREA INLET - STD. PLT. 700-17**

No.	LOCATION	TYPE	"X"	F.L.=
1	STA. 265+99.98, 55.54' RT. N 499145.28, E. 2751872.15	II	X.XX'	1096.50 (18'NW)

**CONSTRUCT CURB INLET - STD. PLT. 700-21**

No.	LOCATION	TYPE	"X"	"A"	"S"	F.L.=
1	STA. 266+20.00, 31.50' LT. N 499160.88, E. 2751784.21	III	X.XX'	X.XX'	X.XX'	1092.60 (18'N) 1092.60 (18'E) 1092.60 (18'SW)
2	STA. 266+20.00, 31.50' RT. N 499164.06, E. 2751847.21	I	X.XX'	X.XX'	X.XX'	1096.35 (18'W) 1096.35 (18'SE)

**CONSTRUCT R.C. FLARED END SECTION w/BAR GRATE**

No.	LOCATION	SIZE	F.L.=
1	STA. 265+93.85, 84.85' LT. N 499132.08, E. 2751732.25	18" I.D.	1090.65 (18'NE)

STA. 262+00.00 TO STA. 268+00.00



**DRAINAGE**

# 36TH STREET

**Q** CONSTRUCT CURB INLET - STD. PLT. 700-21

No.	LOCATION	TYPE	"X"	"A"	"S"	F.L. =
1	STA. 268+22.86, 31.50' RT. N 499366.74, E. 2751836.88	I	X.XX'	X.XX'	X.XX'	1094.55 (18°NE) 1094.55 (18°W)
2	STA. 268+22.86, 31.50' LT. N 499363.39, E. 2751773.96	III	X.XX'	X.XX'	X.XX'	1094.15 (18°S) 1094.15 (18°E)
3	STA. 271+00.00, 31.50' LT. N 499639.57, E. 2751756.49	III	X.XX'	X.XX'	X.XX'	1088.02 (18°N)
4	STA. 272+40.00, 31.50' LT. N 499779.26, E. 2751747.23	III	X.XX'	X.XX'	X.XX'	1082.50 (18°S) 1082.50 (18°N)

**Q** CONSTRUCT REINFORCED CONCRETE PIPE

No.	LOCATION	SIZE	REMARKS
1	C.I. NO. 01 TO C.I. NO. 02	18' X 67'	GR.=0.60%
2	A.I. NO. 01 TO C.I. NO. 01	18' X 32'	GR.=0.47%
3	C.I. NO. 03 TO C.I. NO. 04	18' X 140'	GR.=3.94%
4	C.I. NO. 04 TO C.I. NO. R1	18' X 178'	GR.=3.48%

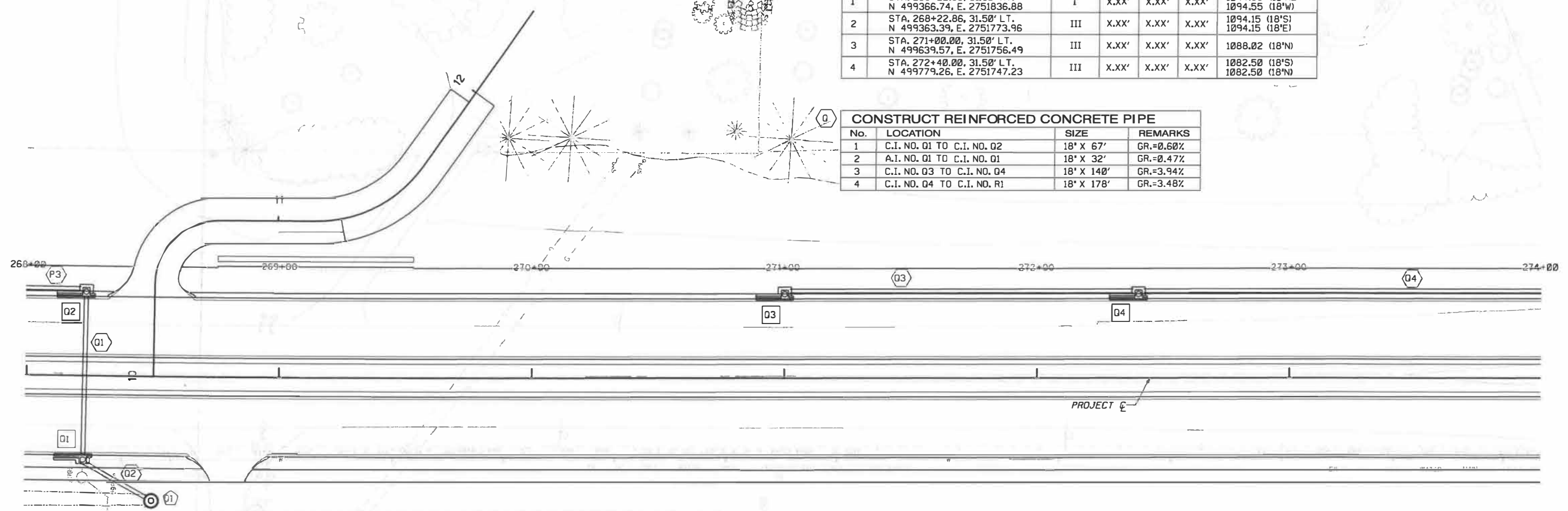

**Q** CONSTRUCT AREA INLET - STD. PLT. 700-17

No.	LOCATION	TYPE	"X"	F.L. =
1	STA. 268+50.00, 49.35' RT. N 499394.93, E. 2751853.21	II	X.XX'	1094.70 (18°SW)



STA. 268+00.00 TO STA. 274+00.00

## DRAINAGE

# 36TH STREET



BLINE AVENUE

BLINE AVENUE

**R CONSTRUCT REINFORCED CONCRETE PIPE**

No.	LOCATION	SIZE	REMARKS
1	C.I. NO. R1 TO C.I. NO. R2	18" X 67'	GR.=1.27%
2	C.I. NO. R2 TO C.I. NO. R4	24" X 359'	GR.=2.12%

**R CONSTRUCT CURB INLET - STD. PLT. 700-21**

No.	LOCATION	TYPE	"X"	"A"	"S"	F.L. =
1	STA. 274+18.00, 31.50' LT. N 499956.87, E. 2751735.45	III	X.XX'	X.XX'	X.XX'	1076.30 (18"S) 1076.30 (18"E)
2	STA. 274+18.00, 31.50' RT. N 499961.04, E. 2751798.31	I	X.XX'	X.XX'	X.XX'	1074.95 (24"N) 1075.95 (18"W)
3	STA. 275+97.71, 33.25' LT. N 500136.07, E. 2751721.81	III	X.XX'	X.XX'	X.XX'	1071.77 (18"N) EXIST 1071.77 (18"S) EXIST
4	STA. 277+76.19, 34.35' RT. N 500319.57, E. 2751776.66	III	X.XX'	X.XX'	X.XX'	1067.35 (24"S) 1067.75 (24"W) EXIST. 1067.35 (24"E) EXIST.

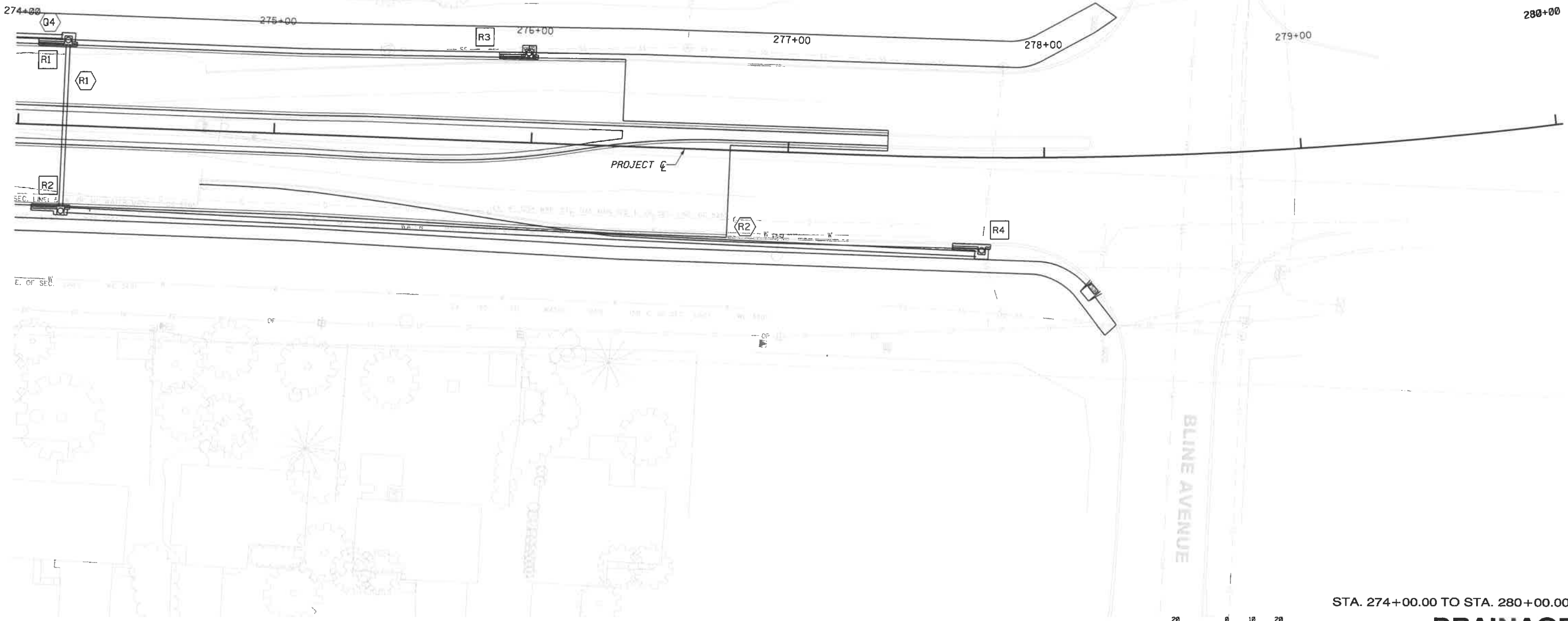

STA. 274+00.00 TO STA. 280+00.00

## DRAINAGE

ROADWAY DESIGN DIVISION

F:\Projects\008-0620-A\40-Design\Microstation\008-0620-A\_RDRB.DGN Sheets\10\_Drainage\0080620dd\_18.dgn  
11:40:0001  
4/22/2018  
zjurak

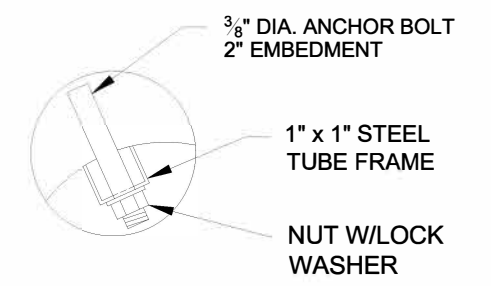
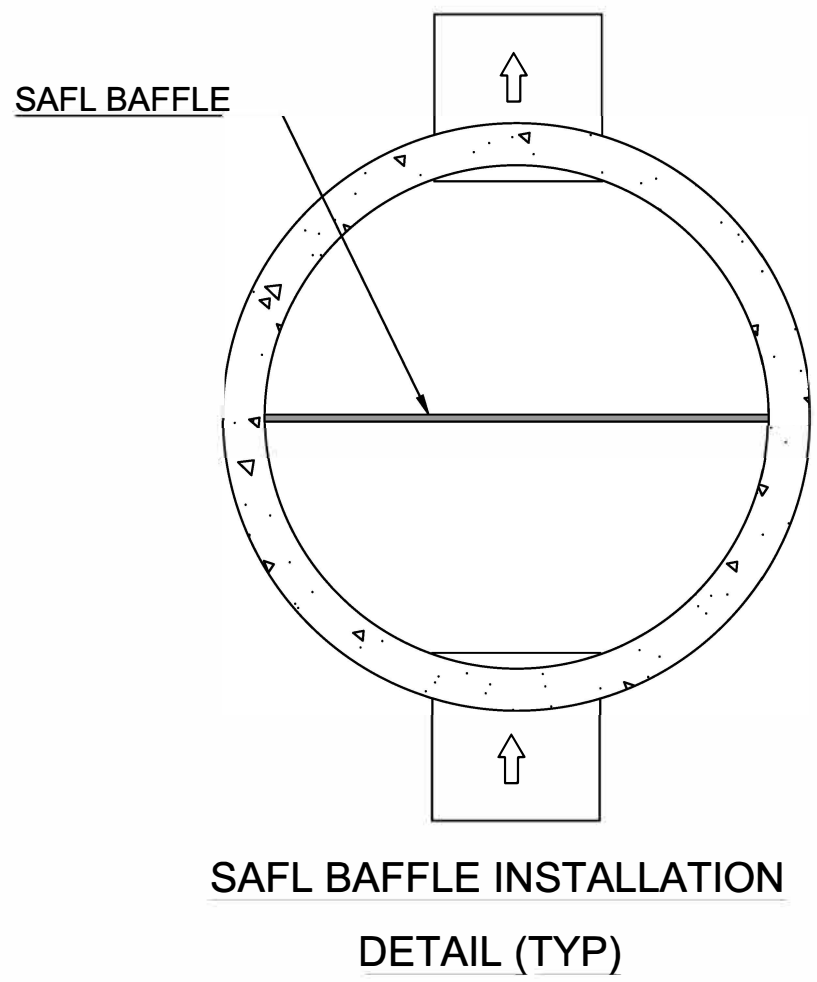
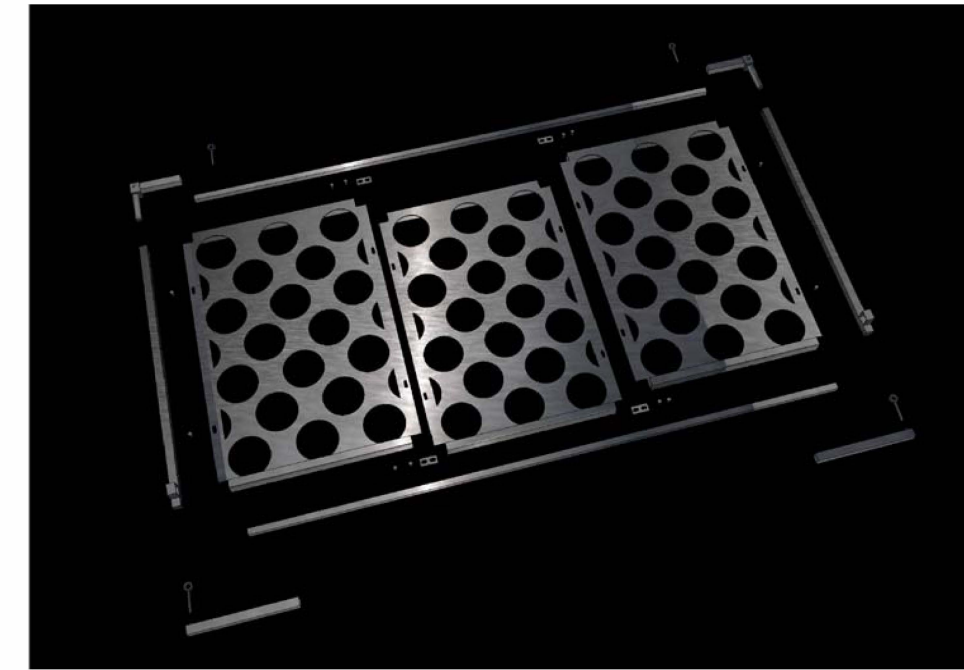
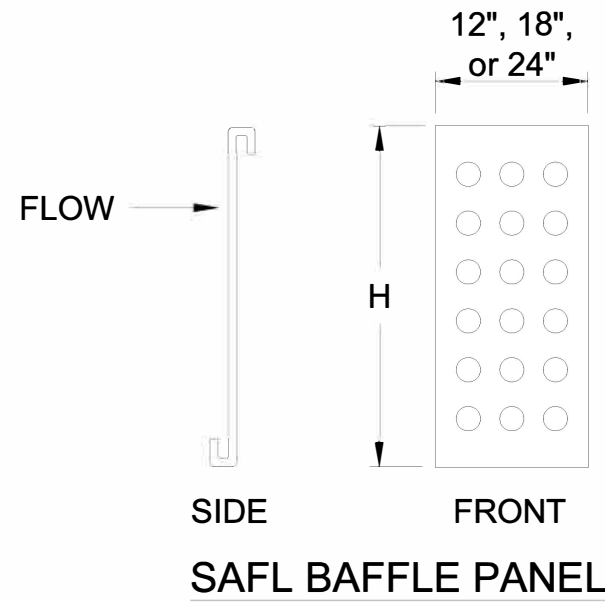
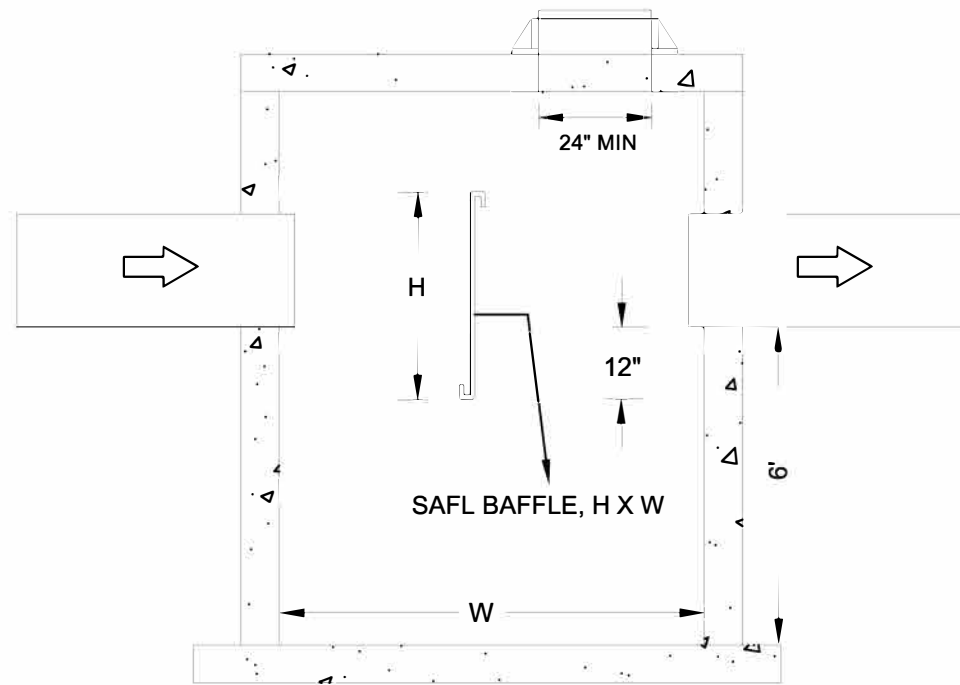

**SAFL BAFFLE ATTACHMENT**  
**BOLT DETAIL**

- NOTES:
- 1) CONTRACTOR MUST VERIFY LOCATION OF CASTING AND STEPS PRIOR TO INSTALLATION OF STRUCTURE.
  - 2) THIS GENERIC DETAIL DOES NOT ENCOMPASS THE SIZING, FIT, AND APPLICABILITY OF THE SAFL BAFFLE FOR THIS SPECIFIC PROJECT. IT IS THE ULTIMATE RESPONSIBILITY OF THE DESIGN ENGINEER TO ASSURE THAT THE DESIGN IS IN COMPLIANCE WITH ALL APPLICABLE LAWS AND REGULATIONS. THE SAFL BAFFLE IS A PATENTED TECHNOLOGY OF THE UNIVERSITY OF MINNESOTA AND UPSTREAM TECHNOLOGIES, INC. NEITHER UPSTREAM TECHNOLOGIES NOR THE UNIVERSITY OF MINNESOTA APPROVES PLANS, SIZING, OR SYSTEM DESIGNS.

**WATER QUALITY STRUCTURE - BETWEEN C1 AND C2 (LOOKING GLASS)**

SAFL Baffle Installation: MOUNT BAFFLE AS CLOSE TO THE CENTER OF THE MANHOLE AS POSSIBLE AND AS PERPENDICULAR AS POSSIBLE TO THE INLET PIPE.

A MINIMUM 24" ID CASTING RING SHOULD BE USED. IF CASTING IS LESS THAN 24", THEN SAFL BAFFLE WILL NEED TO BE INSTALLED PRIOR TO CASTING RING INSTALLATION.

- Structure Diameter (W) = 72 inches
- Top of Cap = TBD
- Inlet Pipe is 36" at Invert Elevation TBD
- Outlet Pipe is 36" at Invert Elevation TBD
- SAFL Baffle bottom Elevation = TBD (12" below Outlet pipe invert)
- Sump Elevation = 6' Below Outlet Pipe Invert
- SAFL Baffle Width (W) = 72 inches
- SAFL Baffle Height (H) = 57 inches

Width of SAFL Baffle is adjustable from 66 inches to 72 inches

PROJECT NAME:

SAFL BAFFLE STANDARD DETAIL  
UPSTREAM TECHNOLOGIES INC.  
600 COUNTY ROAD D WEST, SUITE 14  
NEW BRIGHTON, MN 55112  
651.237.5123



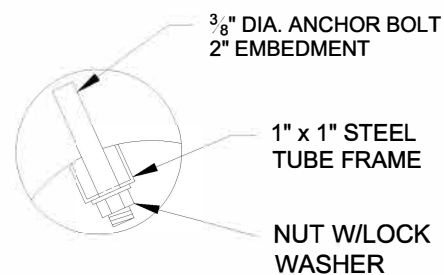
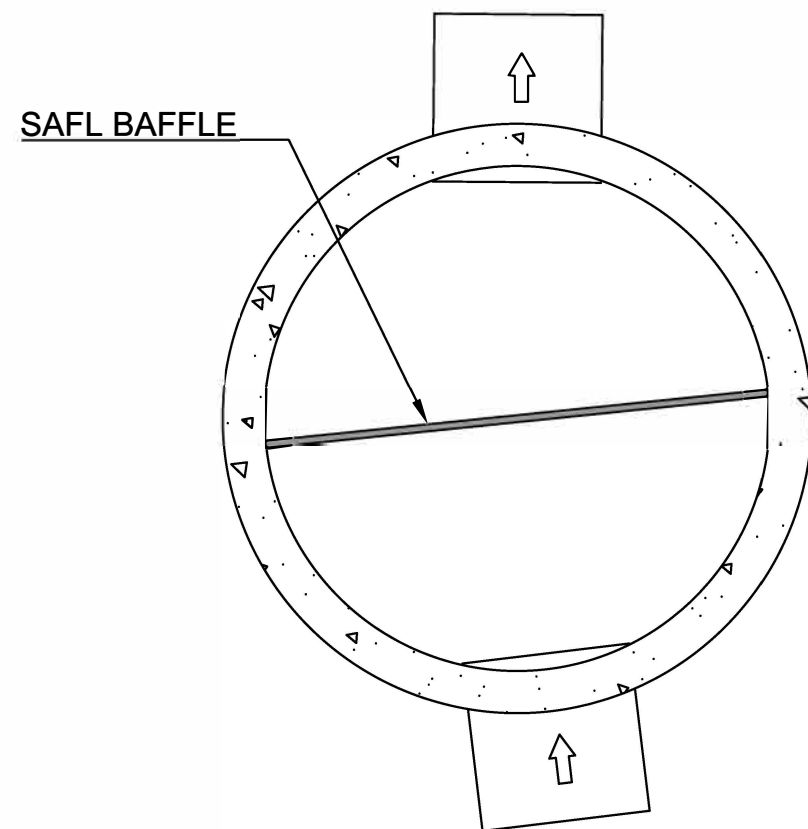
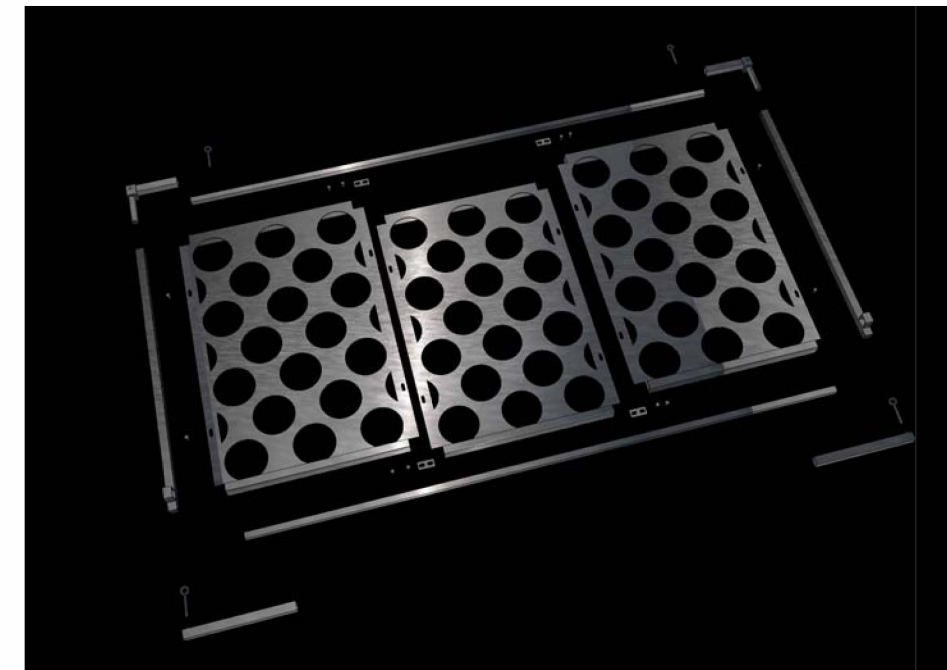
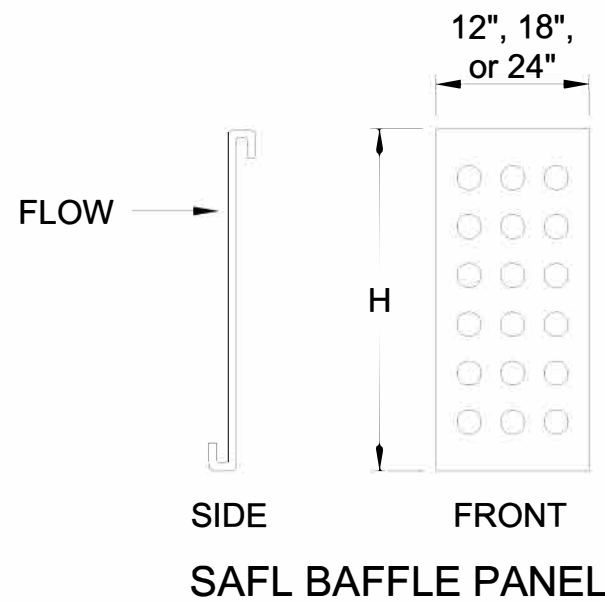
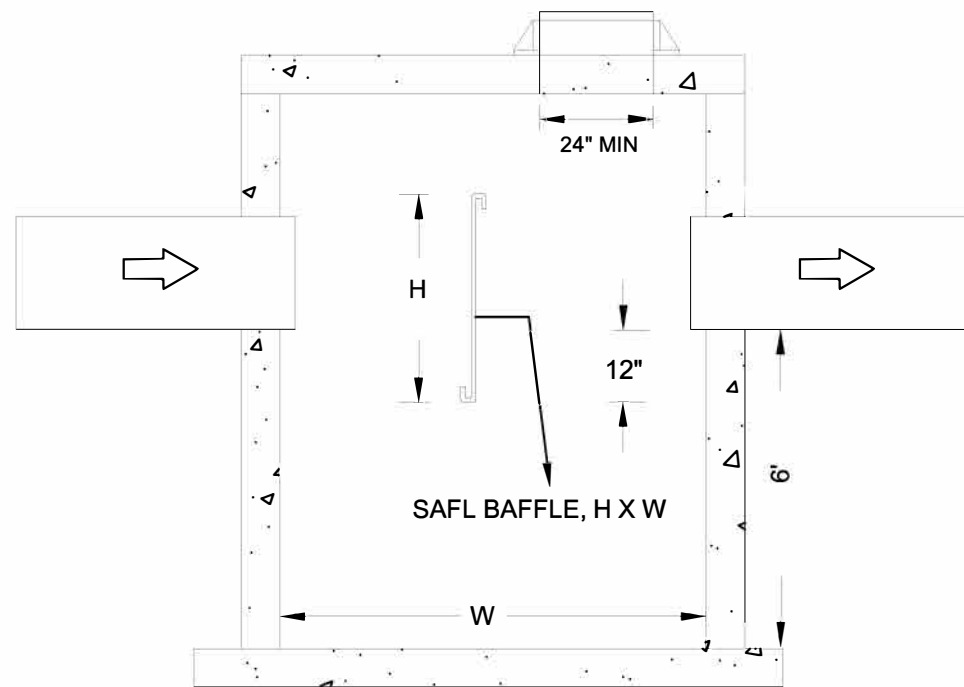

**SAFL BAFFLE ATTACHMENT  
BOLT DETAIL**

**NOTES:**

- 1) CONTRACTOR MUST VERIFY LOCATION OF CASTING AND STEPS PRIOR TO INSTALLATION OF STRUCTURE.
- 2) THIS GENERIC DETAIL DOES NOT ENCOMPASS THE SIZING, FIT, AND APPLICABILITY OF THE SAFL BAFFLE FOR THIS SPECIFIC PROJECT. IT IS THE ULTIMATE RESPONSIBILITY OF THE DESIGN ENGINEER TO ASSURE THAT THE DESIGN IS IN COMPLIANCE WITH ALL APPLICABLE LAWS AND REGULATIONS. THE SAFL BAFFLE IS A PATENTED TECHNOLOGY OF THE UNIVERSITY OF MINNESOTA AND UPSTREAM TECHNOLOGIES, INC. NEITHER UPSTREAM TECHNOLOGIES NOR THE UNIVERSITY OF MINNESOTA APPROVES PLANS, SIZING, OR SYSTEM DESIGNS.

**SAFL BAFFLE INSTALLATION  
DETAIL (TYP)**

**WATER QUALITY STRUCTURE - D1 (LYNNWOOD DR)**

SAFL Baffle Installation: MOUNT BAFFLE AS CLOSE TO THE CENTER OF THE MANHOLE AS POSSIBLE AND AS PERPENDICULAR AS POSSIBLE TO THE INLET PIPE.

A MINIMUM 24" ID CASTING RING SHOULD BE USED. IF CASTING IS LESS THAN 24", THEN SAFL BAFFLE WILL NEED TO BE INSTALLED PRIOR TO CASTING RING INSTALLATION.

- Structure Diameter (W) = 72 inches
- Top of Cap = TBD
- Inlet Pipe is 24" at Invert Elevation TBD
- Outlet Pipe is 24" at Invert Elevation TBD
- SAFL Baffle bottom Elevation = TBD (12" below Outlet pipe invert)
- Sump Elevation = 6' Below Outlet Pipe Invert
- SAFL Baffle Width (W) = 72 inches
- SAFL Baffle Height (H) = 46 inches

Width of SAFL Baffle is adjustable from 66 inches to 72 inches

PROJECT NAME:

SAFL BAFFLE STANDARD DETAIL  
UPSTREAM TECHNOLOGIES INC.  
600 COUNTY ROAD D WEST, SUITE 14  
NEW BRIGHTON, MN 55112  
651.237.5123



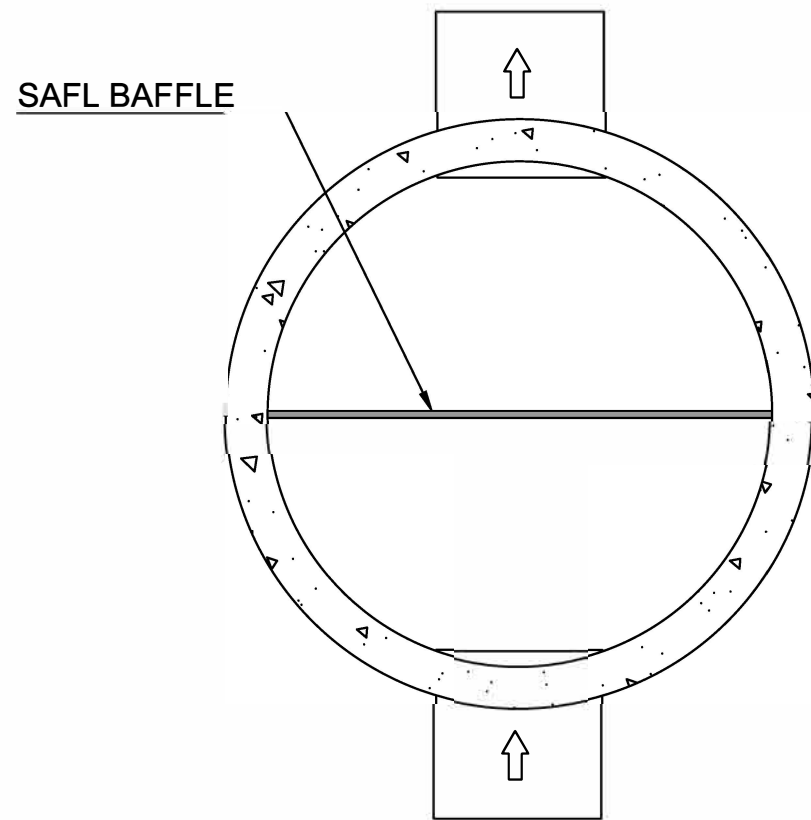
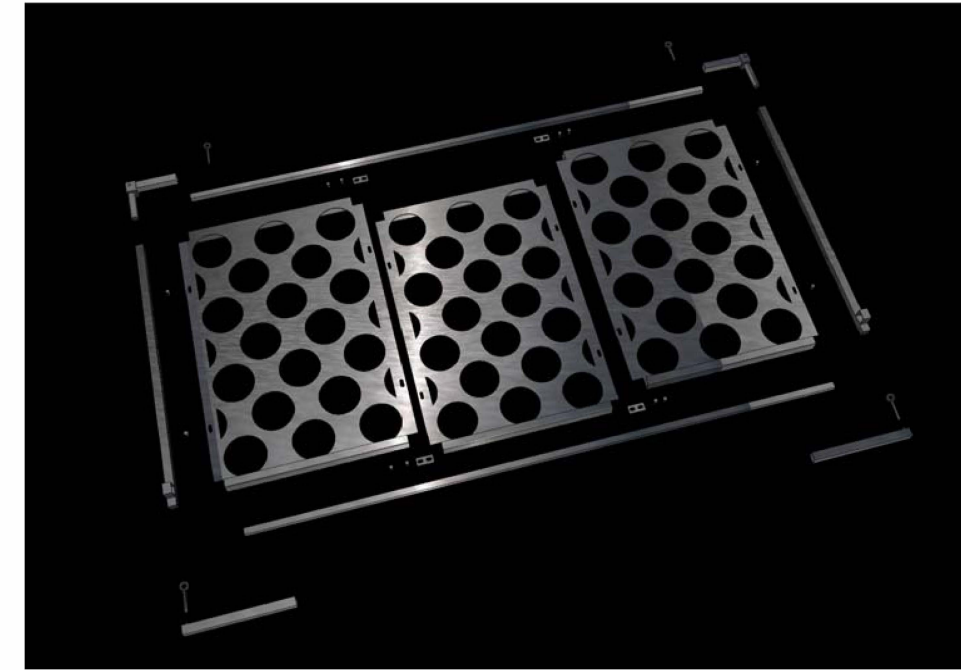
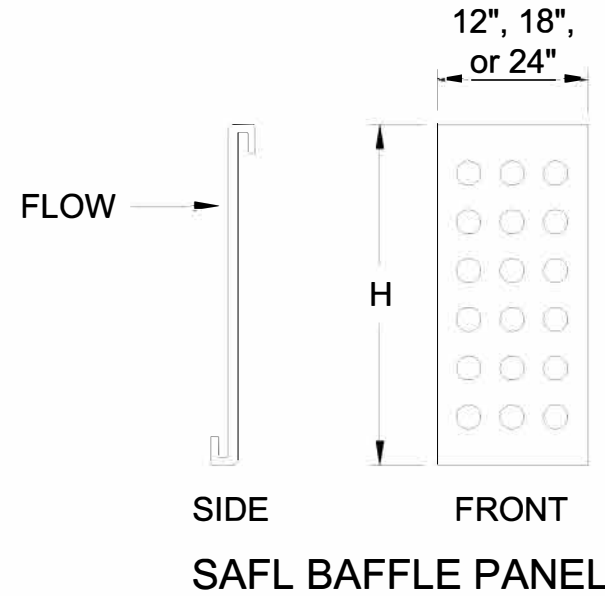
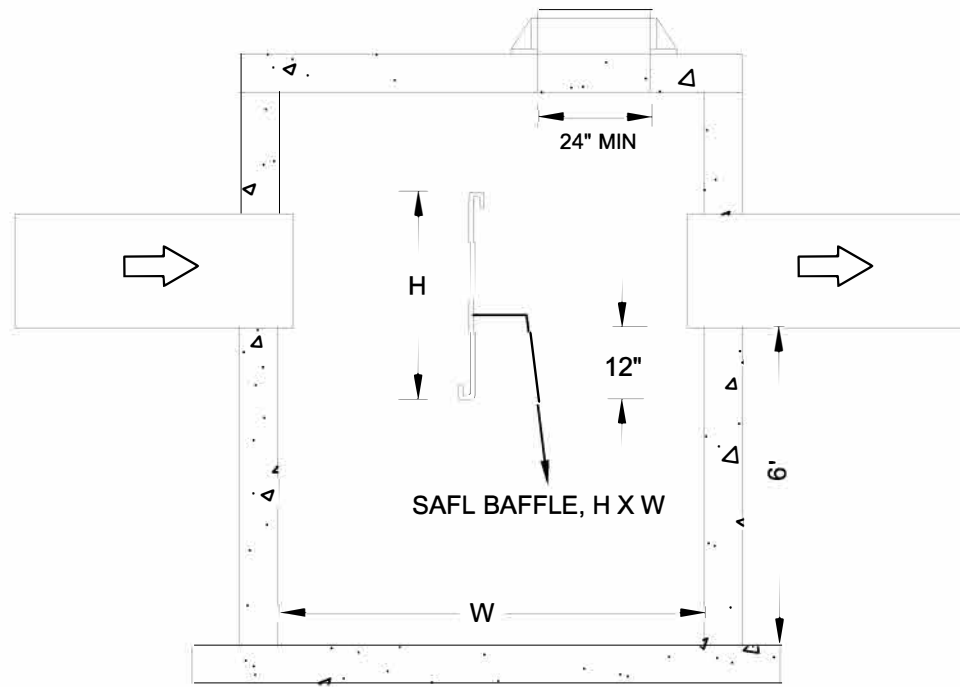

**SAFL BAFFLE INSTALLATION  
DETAIL (TYP)**

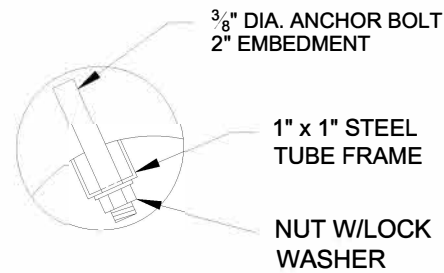

**SAFL BAFFLE ATTACHMENT  
BOLT DETAIL**

**NOTES:**

- 1) CONTRACTOR MUST VERIFY LOCATION OF CASTING AND STEPS PRIOR TO INSTALLATION OF STRUCTURE.
- 2) THIS GENERIC DETAIL DOES NOT ENCOMPASS THE SIZING, FIT, AND APPLICABILITY OF THE SAFL BAFFLE FOR THIS SPECIFIC PROJECT. IT IS THE ULTIMATE RESPONSIBILITY OF THE DESIGN ENGINEER TO ASSURE THAT THE DESIGN IS IN COMPLIANCE WITH ALL APPLICABLE LAWS AND REGULATIONS. THE SAFL BAFFLE IS A PATENTED TECHNOLOGY OF THE UNIVERSITY OF MINNESOTA AND UPSTREAM TECHNOLOGIES, INC. NEITHER UPSTREAM TECHNOLOGIES NOR THE UNIVERSITY OF MINNESOTA APPROVES PLANS, SIZING, OR SYSTEM DESIGNS.

**WATER QUALITY STRUCTURE - E2 (SCHUMANN DR)**

SAFL Baffle Installation: MOUNT BAFFLE AS CLOSE TO THE CENTER OF THE MANHOLE AS POSSIBLE AND AS PERPENDICULAR AS POSSIBLE TO THE INLET PIPE.

A MINIMUM 24" ID CASTING RING SHOULD BE USED. IF CASTING IS LESS THAN 24", THEN SAFL BAFFLE WILL NEED TO BE INSTALLED PRIOR TO CASTING RING INSTALLATION.

- Structure Diameter (W) = 72 inches
- Top of Cap = TBD
- Inlet Pipe is 42" at Invert Elevation TBD
- Outlet Pipe is 42" at Invert Elevation TBD
- SAFL Baffle bottom Elevation = TBD (12" below Outlet pipe invert)
- Sump Elevation = 6' Below Outlet Pipe Invert
- SAFL Baffle Width (W) = 72 inches
- SAFL Baffle Height (H) = 57 inches

Width of SAFL Baffle is adjustable from 66 inches to 72 inches

PROJECT NAME:

SAFL BAFFLE STANDARD DETAIL  
UPSTREAM TECHNOLOGIES INC.  
600 COUNTY ROAD D WEST, SUITE 14  
NEW BRIGHTON, MN 55112  
651.237.5123





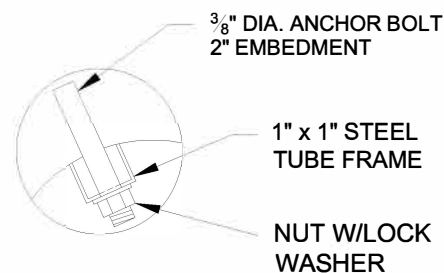
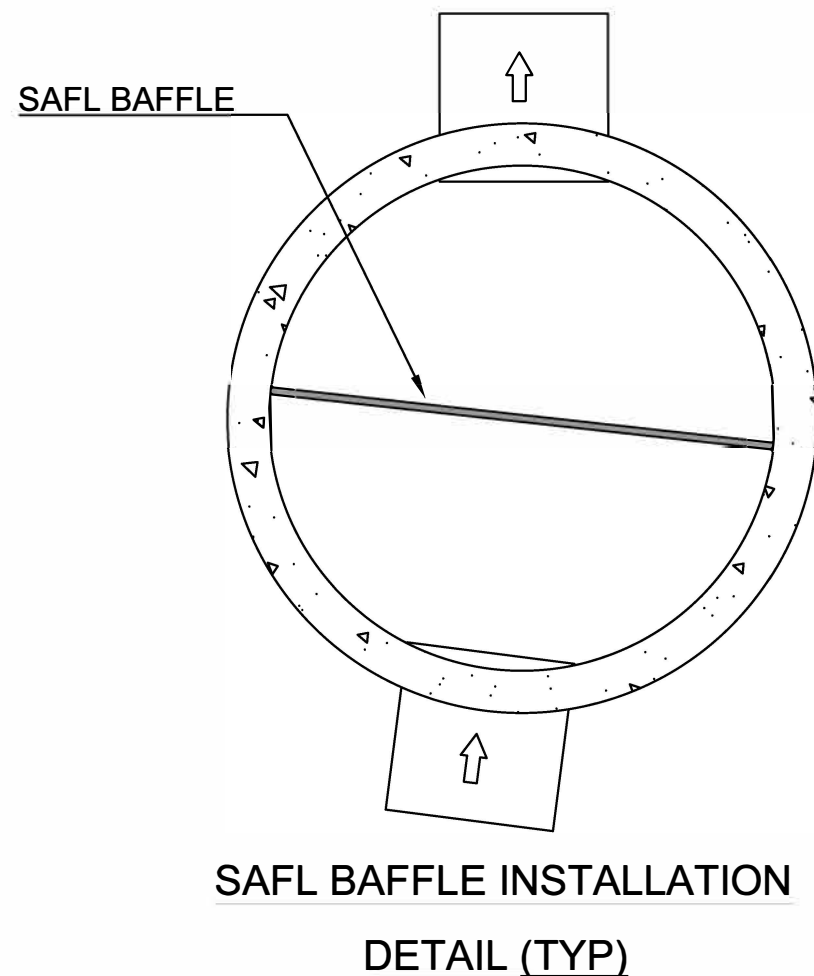
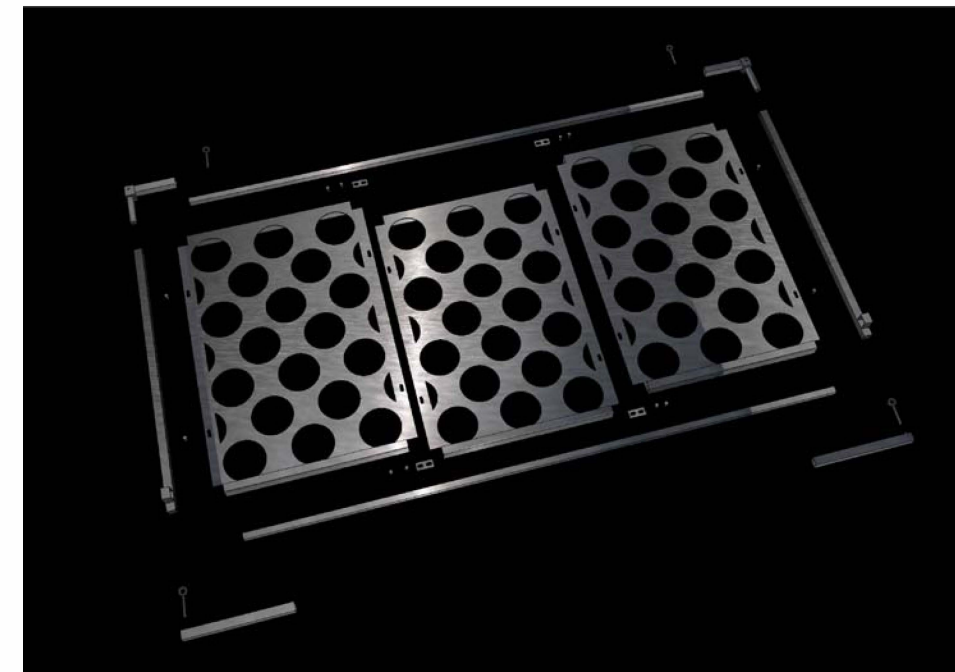
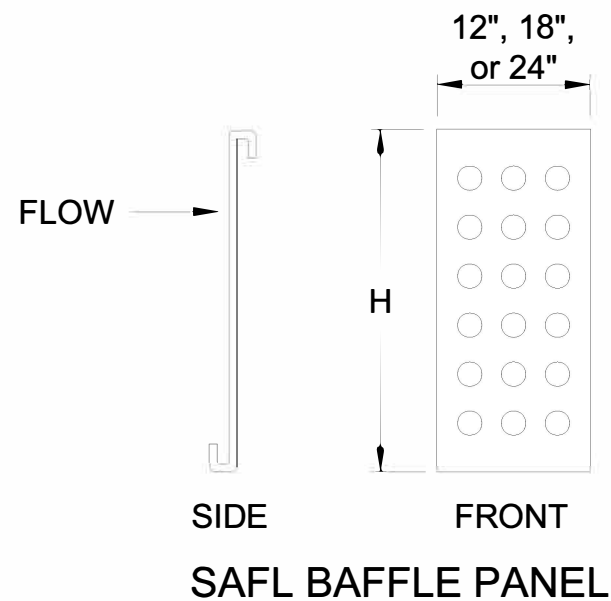
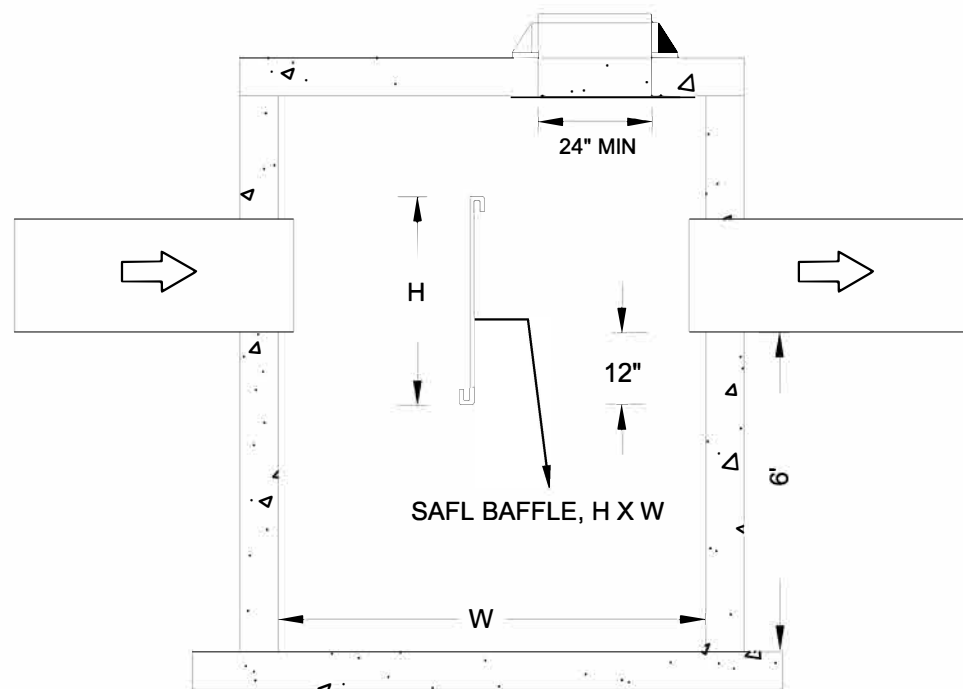

**SAFL BAFFLE ATTACHMENT**  
**BOLT DETAIL**

**NOTES:**

- 1) CONTRACTOR MUST VERIFY LOCATION OF CASTING AND STEPS PRIOR TO INSTALLATION OF STRUCTURE.
- 2) THIS GENERIC DETAIL DOES NOT ENCOMPASS THE SIZING, FIT, AND APPLICABILITY OF THE SAFL BAFFLE FOR THIS SPECIFIC PROJECT. IT IS THE ULTIMATE RESPONSIBILITY OF THE DESIGN ENGINEER TO ASSURE THAT THE DESIGN IS IN COMPLIANCE WITH ALL APPLICABLE LAWS AND REGULATIONS. THE SAFL BAFFLE IS A PATENTED TECHNOLOGY OF THE UNIVERSITY OF MINNESOTA AND UPSTREAM TECHNOLOGIES, INC. NEITHER UPSTREAM TECHNOLOGIES NOR THE UNIVERSITY OF MINNESOTA APPROVES PLANS, SIZING, OR SYSTEM DESIGNS.

**WATER QUALITY STRUCTURE - F3 (LYNNWOOD DR)**

SAFL Baffle Installation: MOUNT BAFFLE AS CLOSE TO THE CENTER OF THE MANHOLE AS POSSIBLE AND AS PERPENDICULAR AS POSSIBLE TO THE INLET PIPE.

A MINIMUM 24" ID CASTING RING SHOULD BE USED. IF CASTING IS LESS THAN 24", THEN SAFL BAFFLE WILL NEED TO BE INSTALLED PRIOR TO CASTING RING INSTALLATION.

- Structure Diameter (W) = 72 inches
- Top of Cap = TBD
- Inlet Pipe is 36" at Invert Elevation TBD
- Outlet Pipe is 36" at Invert Elevation TBD
- SAFL Baffle bottom Elevation = TBD (12" below Outlet pipe invert)
- Sump Elevation = 6' Below Outlet Pipe Invert
- SAFL Baffle Width (W) = 72 inches
- SAFL Baffle Height (H) = 57 inches

Width of SAFL Baffle is adjustable from 66 inches to 72 inches

PROJECT NAME:

SAFL BAFFLE STANDARD DETAIL  
UPSTREAM TECHNOLOGIES INC.  
600 COUNTY ROAD D WEST, SUITE 14  
NEW BRIGHTON, MN 55112  
651.237.5123



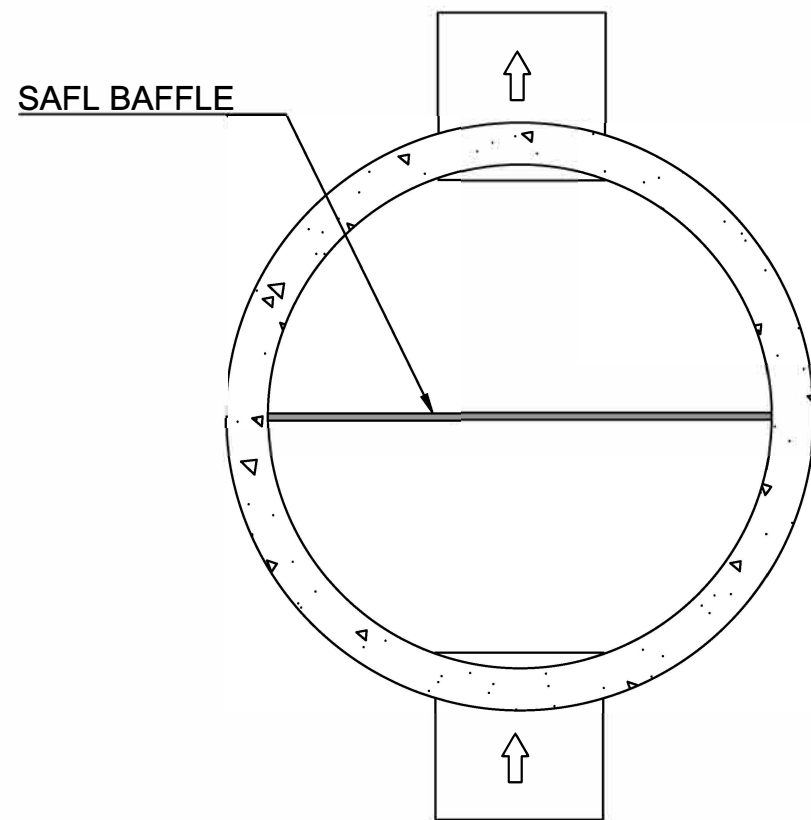
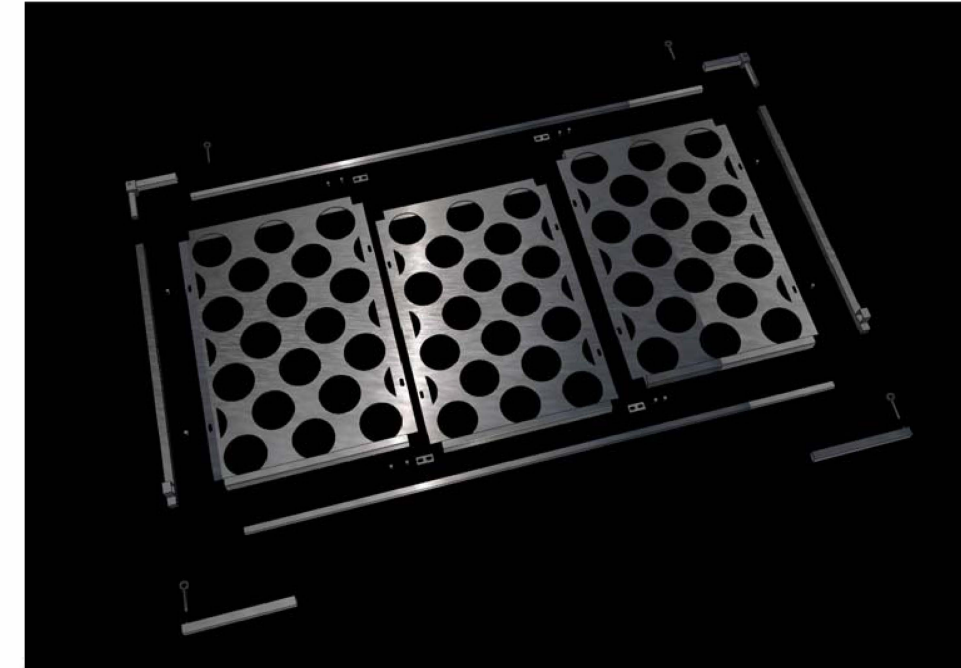
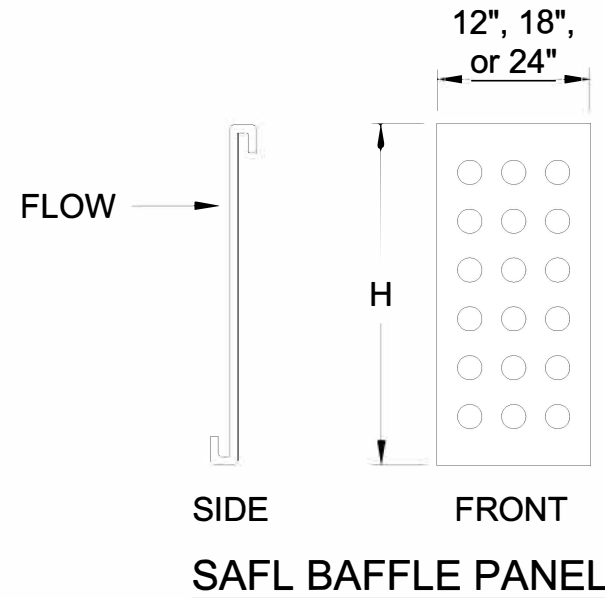
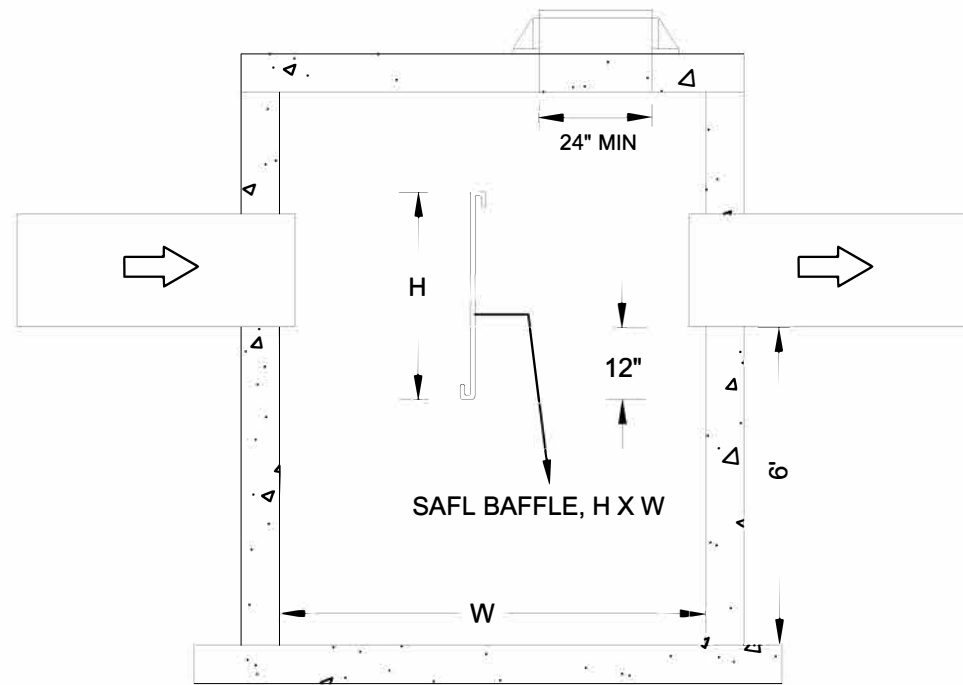

**SAFL BAFFLE INSTALLATION  
DETAIL (TYP)**

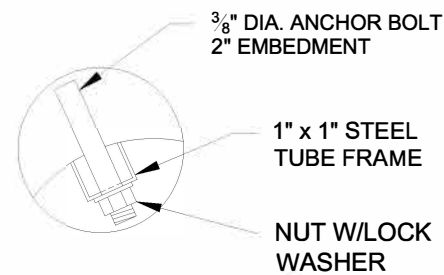

**SAFL BAFFLE ATTACHMENT  
BOLT DETAIL**

**NOTES:**

- 1) CONTRACTOR MUST VERIFY LOCATION OF CASTING AND STEPS PRIOR TO INSTALLATION OF STRUCTURE.
- 2) THIS GENERIC DETAIL DOES NOT ENCOMPASS THE SIZING, FIT, AND APPLICABILITY OF THE SAFL BAFFLE FOR THIS SPECIFIC PROJECT. IT IS THE ULTIMATE RESPONSIBILITY OF THE DESIGN ENGINEER TO ASSURE THAT THE DESIGN IS IN COMPLIANCE WITH ALL APPLICABLE LAWS AND REGULATIONS. THE SAFL BAFFLE IS A PATENTED TECHNOLOGY OF THE UNIVERSITY OF MINNESOTA AND UPSTREAM TECHNOLOGIES, INC. NEITHER UPSTREAM TECHNOLOGIES NOR THE UNIVERSITY OF MINNESOTA APPROVES PLANS, SIZING, OR SYSTEM DESIGNS.

**WATER QUALITY STRUCTURE - G7 (SOUTH OF LEAWOOD)**

SAFL Baffle Installation: MOUNT BAFFLE AS CLOSE TO THE CENTER OF THE MANHOLE AS POSSIBLE AND AS PERPENDICULAR AS POSSIBLE TO THE INLET PIPE.

A MINIMUM 24" ID CASTING RING SHOULD BE USED. IF CASTING IS LESS THAN 24", THEN SAFL BAFFLE WILL NEED TO BE INSTALLED PRIOR TO CASTING RING INSTALLATION.

- Structure Diameter (W) = 72 inches
- Top of Cap = TBD
- Inlet Pipe is 36" at Invert Elevation TBD
- Outlet Pipe is 36" at Invert Elevation TBD
- SAFL Baffle bottom Elevation = TBD (12" below Outlet pipe invert)
- Sump Elevation = 6' Below Outlet Pipe Invert
- SAFL Baffle Width (W) = 72 inches
- SAFL Baffle Height (H) = 57 inches

Width of SAFL Baffle is adjustable from 66 inches to 72 inches

PROJECT NAME:

SAFL BAFFLE STANDARD DETAIL  
UPSTREAM TECHNOLOGIES INC.  
600 COUNTY ROAD D WEST, SUITE 14  
NEW BRIGHTON, MN 55112  
651.237.5123



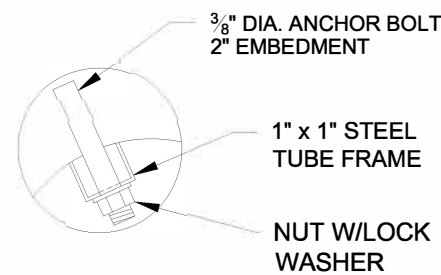
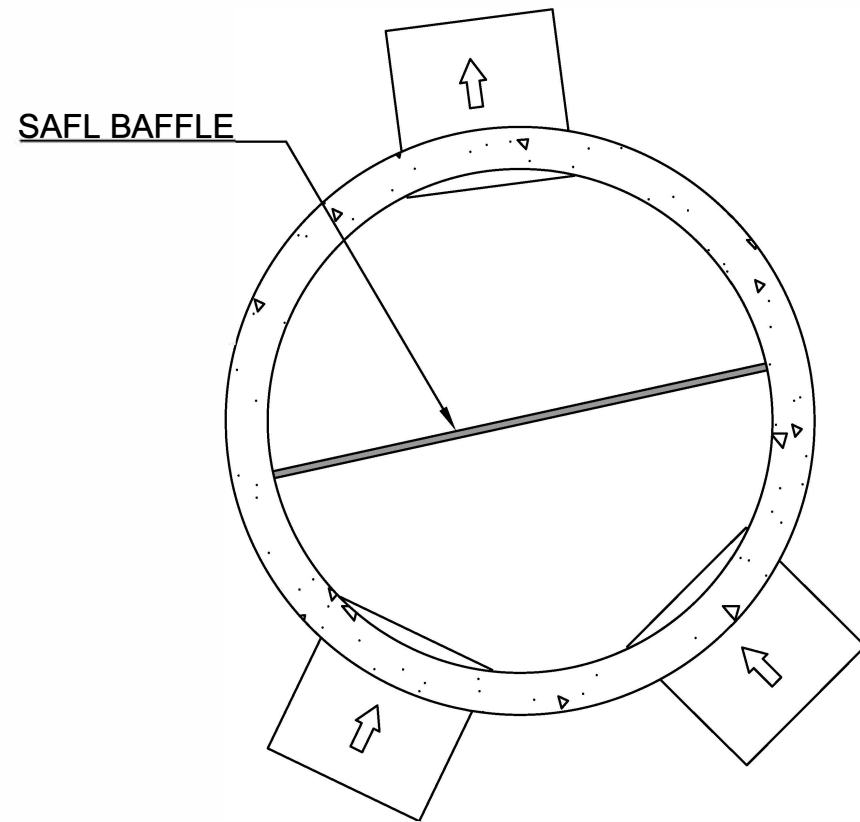
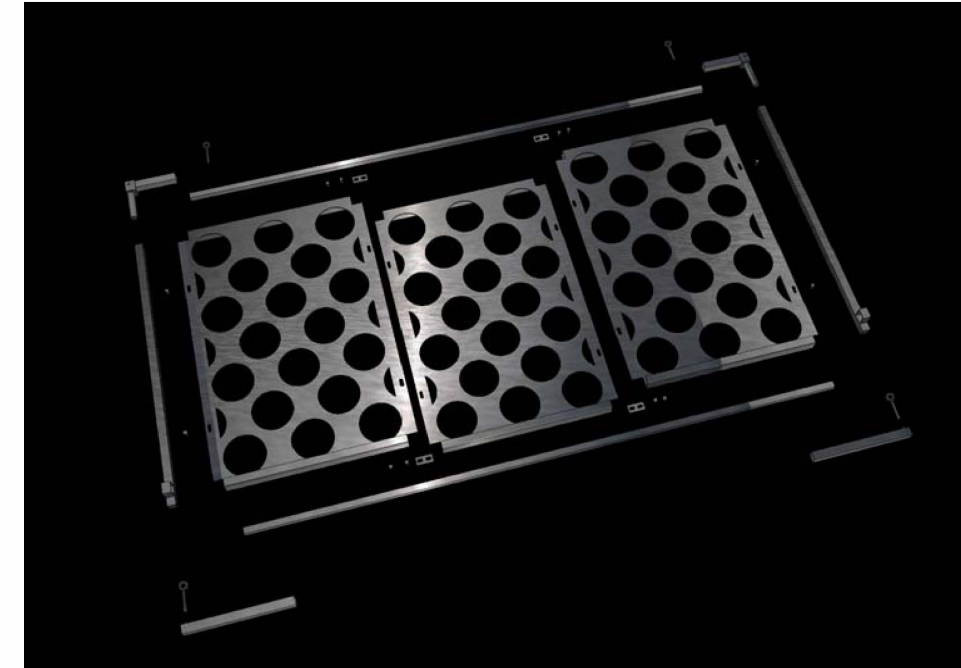
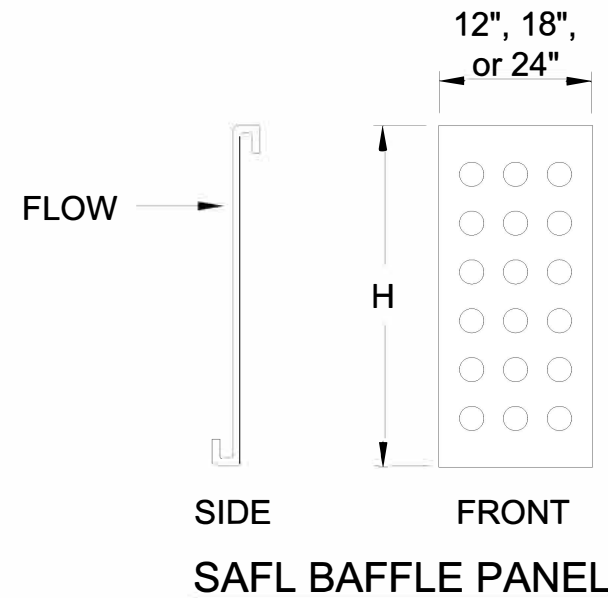
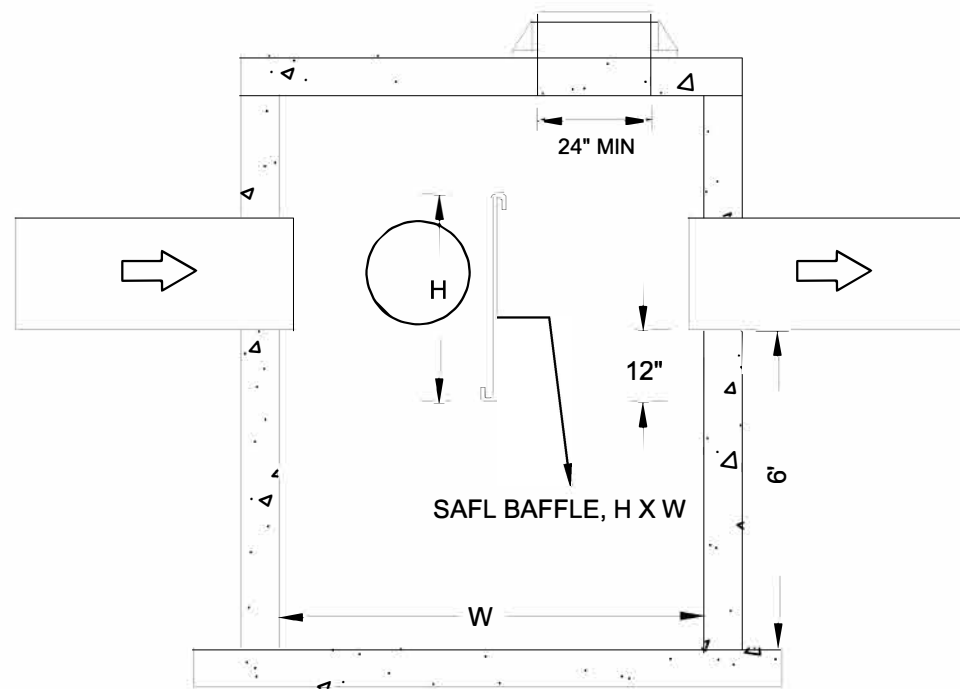

**SAFL BAFFLE ATTACHMENT**  
**BOLT DETAIL**

**NOTES:**

- 1) CONTRACTOR MUST VERIFY LOCATION OF CASTING AND STEPS PRIOR TO INSTALLATION OF STRUCTURE.
- 2) THIS GENERIC DETAIL DOES NOT ENCOMPASS THE SIZING, FIT, AND APPLICABILITY OF THE SAFL BAFFLE FOR THIS SPECIFIC PROJECT. IT IS THE ULTIMATE RESPONSIBILITY OF THE DESIGN ENGINEER TO ASSURE THAT THE DESIGN IS IN COMPLIANCE WITH ALL APPLICABLE LAWS AND REGULATIONS. THE SAFL BAFFLE IS A PATENTED TECHNOLOGY OF THE UNIVERSITY OF MINNESOTA AND UPSTREAM TECHNOLOGIES, INC. NEITHER UPSTREAM TECHNOLOGIES NOR THE UNIVERSITY OF MINNESOTA APPROVES PLANS, SIZING, OR SYSTEM DESIGNS.

**SAFL BAFFLE INSTALLATION**  
**DETAIL (TYP)**

**WATER QUALITY STRUCTURE - H1 (NORTH OF LEAWOOD)**

SAFL Baffle Installation: MOUNT BAFFLE AS CLOSE TO THE CENTER OF THE MANHOLE AS POSSIBLE AND AS PERPENDICULAR AS POSSIBLE TO THE RESULTANT OF THE FLOWS FROM THE TWO INLET PIPES.

A MINIMUM 24" ID CASTING RING SHOULD BE USED. IF CASTING IS LESS THAN 24", THEN SAFL BAFFLE WILL NEED TO BE INSTALLED PRIOR TO CASTING RING INSTALLATION.

- Structure Diameter (W) = 72 inches
- Top of Cap = TBD
- Inlet Pipe (SE) is 30" at Invert Elevation TBD
- Inlet Pipe (NE) is 24" at Invert Elevation TBD
- Outlet Pipe is 30" at Invert Elevation TBD
- SAFL Baffle bottom Elevation = TBD (12" below Outlet pipe invert)
- Sump Elevation = 6' Below Outlet Pipe Invert
- SAFL Baffle Width (W) = 72 inches
- SAFL Baffle Height (H) = 46 inches

Width of SAFL Baffle is adjustable from 66 inches to 72 inches

PROJECT NAME:

SAFL BAFFLE STANDARD DETAIL  
UPSTREAM TECHNOLOGIES INC.  
600 COUNTY ROAD D WEST, SUITE 14  
NEW BRIGHTON, MN 55112  
651.237.5123



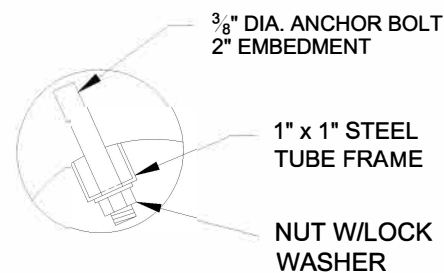
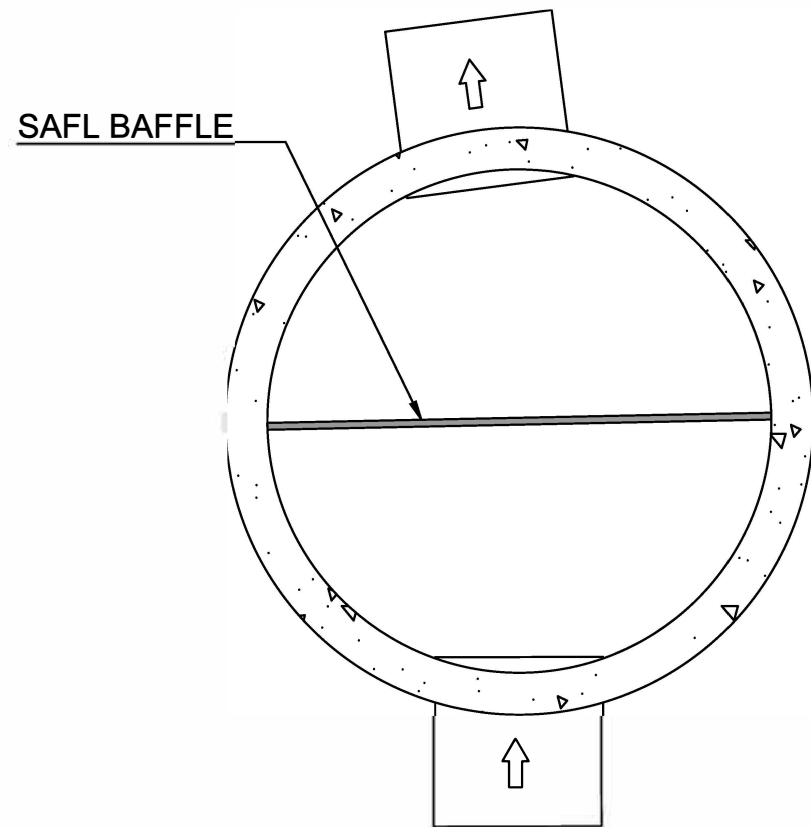
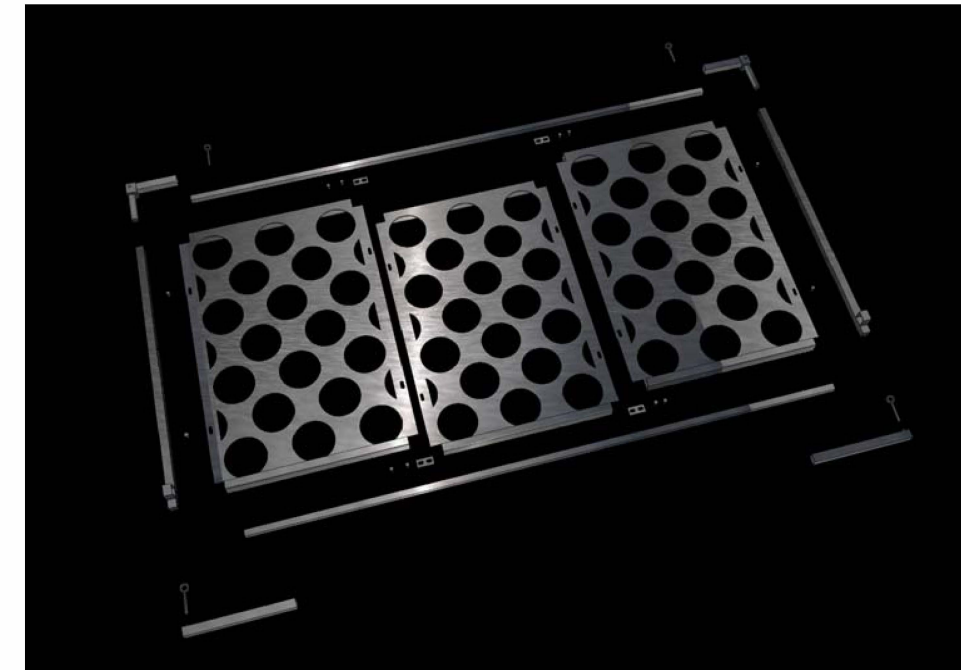
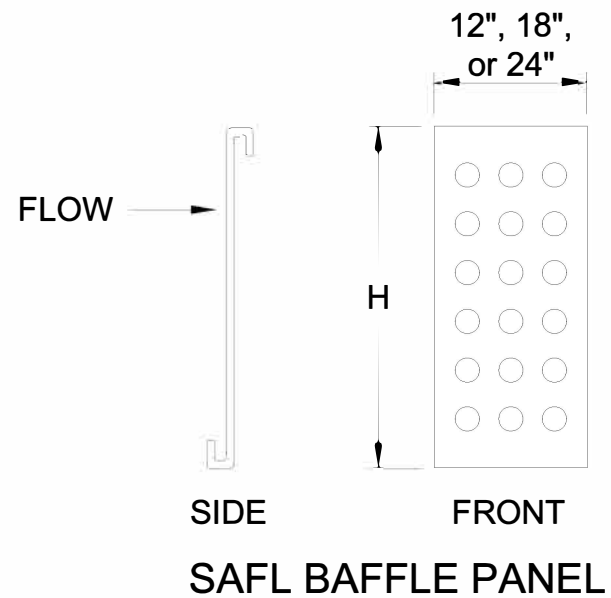
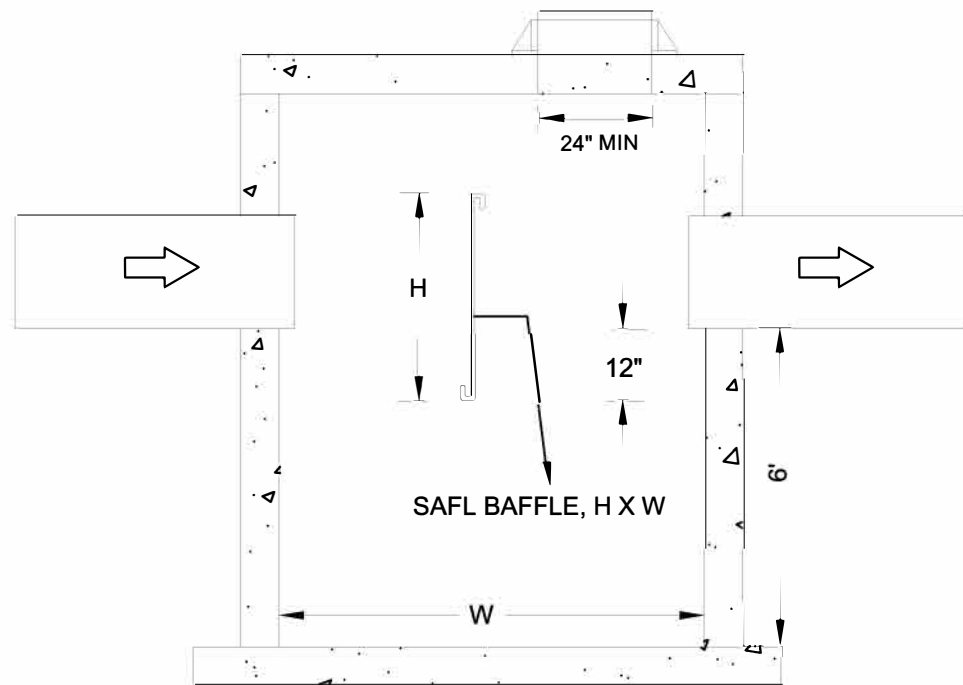

**SAFL BAFFLE ATTACHMENT**  
**BOLT DETAIL**

**NOTES:**

- 1) CONTRACTOR MUST VERIFY LOCATION OF CASTING AND STEPS PRIOR TO INSTALLATION OF STRUCTURE.
- 2) THIS GENERIC DETAIL DOES NOT ENCOMPASS THE SIZING, FIT, AND APPLICABILITY OF THE SAFL BAFFLE FOR THIS SPECIFIC PROJECT. IT IS THE ULTIMATE RESPONSIBILITY OF THE DESIGN ENGINEER TO ASSURE THAT THE DESIGN IS IN COMPLIANCE WITH ALL APPLICABLE LAWS AND REGULATIONS. THE SAFL BAFFLE IS A PATENTED TECHNOLOGY OF THE UNIVERSITY OF MINNESOTA AND UPSTREAM TECHNOLOGIES, INC. NEITHER UPSTREAM TECHNOLOGIES NOR THE UNIVERSITY OF MINNESOTA APPROVES PLANS, SIZING, OR SYSTEM DESIGNS.

**SAFL BAFFLE INSTALLATION**  
**DETAIL (TYP)**

**WATER QUALITY STRUCTURE - K1 (NORTH OF CAPEHORT)**

SAFL Baffle Installation: MOUNT BAFFLE AS CLOSE TO THE CENTER OF THE MANHOLE AS POSSIBLE AND AS PERPENDICULAR AS POSSIBLE TO THE INLET PIPE.

A MINIMUM 24" ID CASTING RING SHOULD BE USED. IF CASTING IS LESS THAN 24", THEN SAFL BAFFLE WILL NEED TO BE INSTALLED PRIOR TO CASTING RING INSTALLATION.

- Structure Diameter (W) = 72 inches
- Top of Cap = TBD
- Inlet Pipe is 30" at Invert Elevation TBD
- Outlet Pipe is 36" at Invert Elevation TBD
- SAFL Baffle bottom Elevation = TBD (12" below Outlet pipe invert)
- Sump Elevation = 6' Below Outlet Pipe Invert
- SAFL Baffle Width (W) = 72 inches
- SAFL Baffle Height (H) = 46 inches

Width of SAFL Baffle is adjustable from 66 inches to 72 inches

PROJECT NAME:

SAFL BAFFLE STANDARD DETAIL  
UPSTREAM TECHNOLOGIES INC.  
600 COUNTY ROAD D WEST, SUITE 14  
NEW BRIGHTON, MN 55112  
651.237.5123



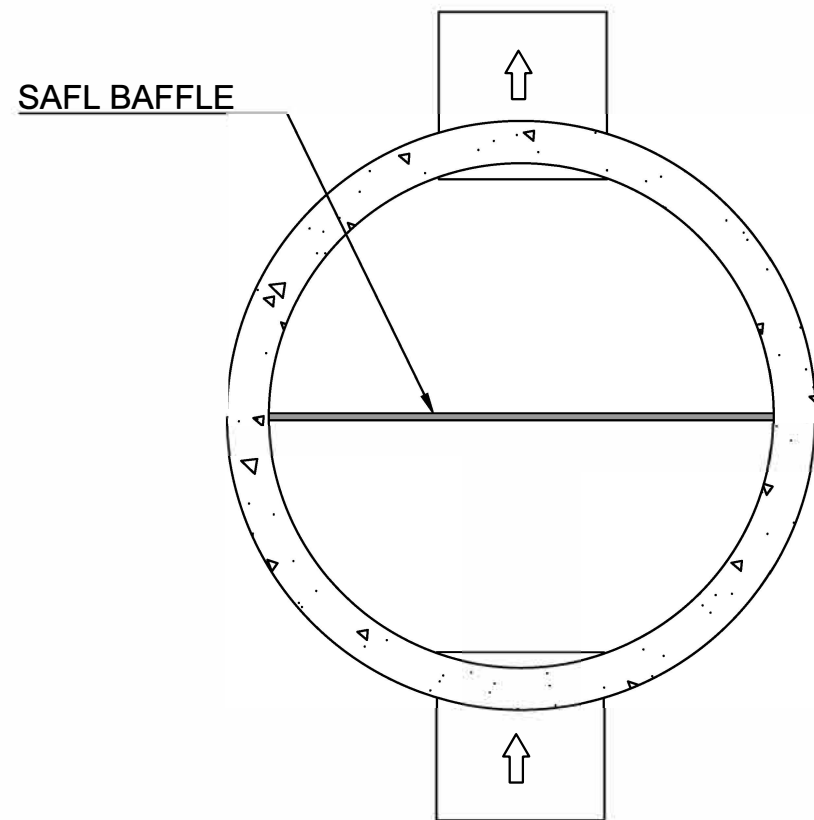
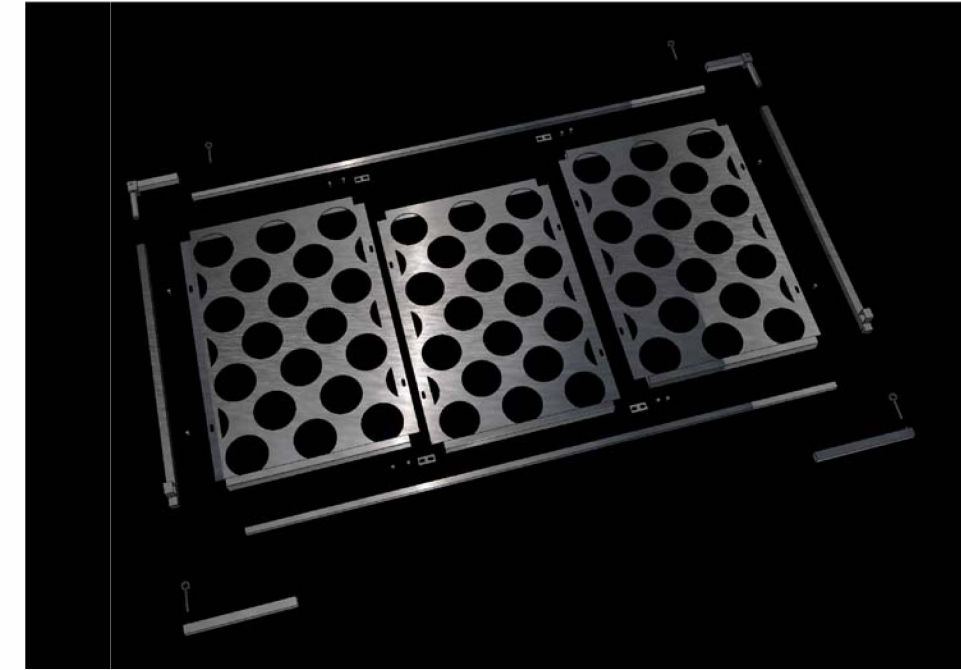
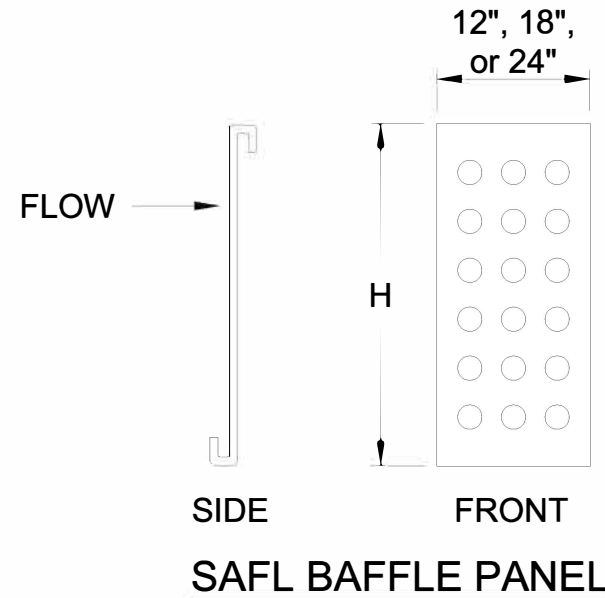
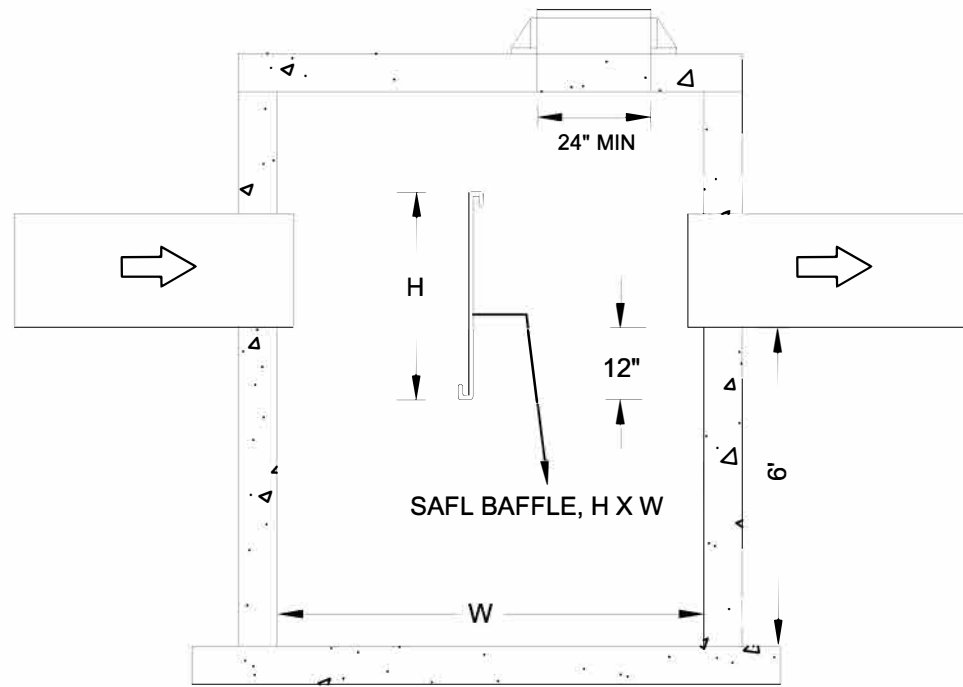

**SAFL BAFFLE INSTALLATION  
DETAIL (TYP)**

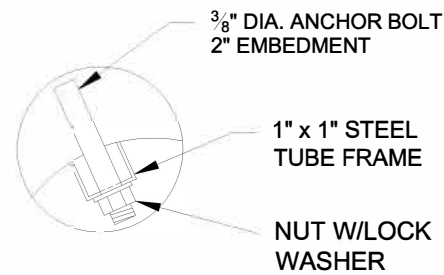

**SAFL BAFFLE ATTACHMENT  
BOLT DETAIL**

**NOTES:**

- 1) CONTRACTOR MUST VERIFY LOCATION OF CASTING AND STEPS PRIOR TO INSTALLATION OF STRUCTURE.
- 2) THIS GENERIC DETAIL DOES NOT ENCOMPASS THE SIZING, FIT, AND APPLICABILITY OF THE SAFL BAFFLE FOR THIS SPECIFIC PROJECT. IT IS THE ULTIMATE RESPONSIBILITY OF THE DESIGN ENGINEER TO ASSURE THAT THE DESIGN IS IN COMPLIANCE WITH ALL APPLICABLE LAWS AND REGULATIONS. THE SAFL BAFFLE IS A PATENTED TECHNOLOGY OF THE UNIVERSITY OF MINNESOTA AND UPSTREAM TECHNOLOGIES, INC. NEITHER UPSTREAM TECHNOLOGIES NOR THE UNIVERSITY OF MINNESOTA APPROVES PLANS, SIZING, OR SYSTEM DESIGNS.

**WATER QUALITY STRUCTURE - N1 (LOCKBOURNE DR)**

SAFL Baffle Installation: MOUNT BAFFLE AS CLOSE TO THE CENTER OF THE MANHOLE AS POSSIBLE AND AS PERPENDICULAR AS POSSIBLE TO THE INLET PIPE.

A MINIMUM 24" ID CASTING RING SHOULD BE USED. IF CASTING IS LESS THAN 24", THEN SAFL BAFFLE WILL NEED TO BE INSTALLED PRIOR TO CASTING RING INSTALLATION.

- Structure Diameter (W) = 72 inches
- Top of Cap = TBD
- Inlet Pipe is 30" at Invert Elevation TBD
- Outlet Pipe is 30" at Invert Elevation TBD
- SAFL Baffle bottom Elevation = TBD (12" below Outlet pipe invert)
- Sump Elevation = 6' Below Outlet Pipe Invert
- SAFL Baffle Width (W) = 72 inches
- SAFL Baffle Height (H) = 46 inches

Width of SAFL Baffle is adjustable from 66 inches to 72 inches

PROJECT NAME:

SAFL BAFFLE STANDARD DETAIL  
UPSTREAM TECHNOLOGIES INC.  
600 COUNTY ROAD D WEST, SUITE 14  
NEW BRIGHTON, MN 55112  
651.237.5123

